

# DEVELON

Wheel Loader

# DL580-5





# THE NEW DL580-5 WHEEL LOADER HAS IT ALL





# ALL NEW DL580-5 WHEEL LOADER DELIVERS TOTAL SOLUTION FOR YOUR BUSINESS WITH ENHANCED POWER AND RELIABILITY.

## TOTAL COST OF OWNERSHIP :

Minimising your operating costs is at the heart of the DEVELON wheel loaders' design, every day. DEVELON wheel loaders achieve world best level of fuel efficiency aligning with advanced features and design.

## BEST PRODUCTIVITY :

Thanks to their robust design and the use of high-quality components, the DEVELON wheel loaders deliver very high performance – ensuring the best productivity and reliability.

## IMPROVED ERGONOMICS :

More space, better visibility, high comfortable features, and plenty of storage space make it easy to work.





# TOP PERFORMANCE AND FUEL EFFICIENCY

**EXCEPTIONAL POWER – COMBINED WITH THE FINEST WORKMANSHIP  
– RESULTS IN A MACHINE THAT PERFORMS AT THE HIGHEST LEVEL.  
THE DL580-5 ENHANCE YOUR OUTPUT FROM EVERY ANGLE :**

- Impressive breakout force and high traction make penetration easy and allow you to tackle the hardest materials.
- Powerful hydraulic system makes work quick and efficient  
The combination of these features gives DEVELON wheel loaders excellent penetration power, ensuring optimum bucket load in each cycle.

## **NEW ENGINE / HIGHER TORQUE**

The DL580-5 are equipped with Scania engines. Famous for excellent fuel efficiency, reliability and long service life, these engines combine exceptional power output and high torque at low revs. Common-rail fuel injection is combined with a Variable Geometry Turbocharger for faster machine response, even at very low speed.



## **TRANSMISSION**

The DEVELON ZF transmission has 4 gears to boost acceleration performance, especially on climbs with the lock-up. The gear ratios are optimized and smooth, and shock-free shifts contribute to the high overall level of operator comfort. Traction force is also maximized. Together, these qualities enable high working speed in all conditions. The transmission has 3 operating modes :

- Manual
- Automatic (working, 1st to 4th gear)
- Automatic (travelling, 2nd to 4th gear)  
An automatic kick-down improves the machine's penetration into the pile.







### LOAD-SENSING HYDRAULIC CLOSED CENTER SYSTEM

This system provides maximum hydraulic performance, without producing excess capacity, thus saving fuel and extending the lifetime and reliability of vital components (such as the pumps and the main control valves).



### TAILORED PERFORMANCE

You can select from 3 different working modes : Eco, Normal and Power, while the Power-up function lets you switch the machine into a higher working mode with lower transmission shift intervals by fully applying the acceleration pedal.

### SAVE FUEL, SAVE MONEY

To improve your fuel efficiency, an auto shut-down reduces the idle time of the engine, to prevent over-consumption and useless operating hours. You can easily set the auto shut-down (to stop the engine after 3 to 60 minutes) via the LCD display.

### ECO GAUGE

It shows the average fuel efficiency for 1 minute of operation.



# RELIABILITY, THE HABIT OF A LIFETIME

## "DEPENDABLE PERFORMANCE FOR LOW LIFETIME COST"

-DEVELON has been building heavy construction equipment for 40 years. This extensive experience is reflected in the superior design and development of our wheel loaders and by an extensive logistics network. Plus, our standard machines include a wide range of features at no extra cost (other manufacturers offer these only as options).





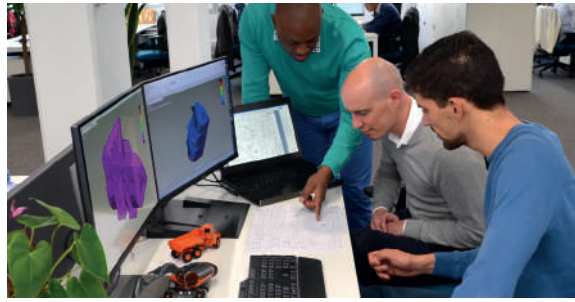

### DESIGNED TO LAST

We pay the closest attention to the design and manufacture of structural components. Finite Element Analysis is used to ensure an extended lifetime for main structures such as the chassis, joints and lift arm. Then, after modeling, they are subjected to intensive laboratory and field testing in extreme conditions. Ongoing statistical analysis is used to continually increase reliability.

### DURABLE STEEL PARTS

Rear parts – such as the radiator grille, engine bonnet and fenders – are made of solid steel. They're also designed for easy repair, reducing the need to replace them if they are damaged.

### AUTOMATIC HYDRAULIC DIFFERENTIAL LOCKS

Hydraulic differential lock on the front engages automatically to ensure maximum tractive effort with a lock of 100% and driving ease. Muddy and slippery areas can be navigated by the operator with the manual foot control. These features also reduce the risk of skidding and prevent excessive tire wear. The brake discs in the planetary reduction gears are reinforced, ensuring long hours of operation and easy maintenance access.

### AXLE OIL COOLER

To ensure you the maximum performance from your machine, even in very hard applications, the axles can be equipped with an oil cooling system, thus ensuring proper operation in any conditions.

### ARTICULATION HINGES

The robust hinges feature a clean and solid design – and the 40° articulation angle and steering radius are the best in their class.

### EXHAUST

The inner exhaust pipe sucks air out of the engine compartment through an outer pipe – this "chimney" effect provides constant air circulation and prevents deposits of flammable material on hot parts.

### AUTO-LUBE (OPTIONAL)

The DL580-5 is standard equipped with an automatic central greasing system : 'Auto-lube' protects components for longer machine lifetime.

### ORFS (O-RING FACE SEAL)

All hydraulic lines, even the low pressure circuits, are sealed with ORFS couplings to prevent leaks.

### ENGINE PRE-CLEANER

This basic feature is a cyclone-separator type, which separates more than 99% of 20 micron and larger particles. In addition to extending the air filter's lifetime, it also ensures better combustion and a longer engine lifetime.

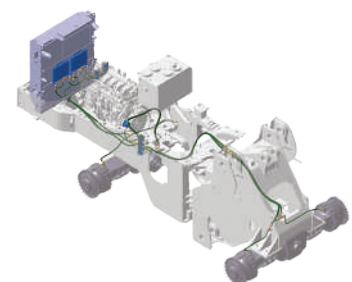



# OPERATING IN COMFORT



1. Color rear-view camera
2. Emergency exit
3. Cup holders and a lot of other storage space in the cab
4. Intuitive and grouped controls
5. Fully adjustable console with right armrest and joystick

6. Color LCD monitor panel
7. Steering wheel adjustable in all directions
8. Electric joystick steering with F/R on left armrest
9. Premium heated air-suspension seat with many set-up options
10. Fire extinguisher bracket





### OPERATOR ENVIRONMENT

A modern and attractive work space offers generous head room, and seat movement provides lots of leg room. Interior materials are selected for their high quality and easy cleaning. In addition, your belongings are right at hand, thanks to several storage boxes throughout the cab.

### COMFORTABLE AUTOMATIC LIFT ARM

Save time and reduce the number of operations with the "lift arm raise kick-out" and "return to dig" system. These functions are operated electronically from inside the cab. Different types of control are available, joystick with FNR and proportional thumbwheel for auxiliary hydraulic line, or fingertip control levers also with FNR feature.

### HIGH-COMFORT AIR SUSPENSION SEAT

With vertical and horizontal suspension, the ultra-comfortable, heated and fully adjustable Grammer seat is featured as standard, giving you the feeling of being comfortably installed in your own sofa.

### LOAD ISOLATION SYSTEM

This standard feature provides a smooth ride over rough ground, operator comfort, and reduced cycle times due to improved vehicle stability in movement. Higher productivity and better fuel efficiency while performing load & carry applications. Speed for automatic activation is adjustable by the operator.

### ACCURATE & SMOOTH JOYSTICK STEERING

Keep your concentration and reduce strain with the comfortable joystick steering integrated on the armrest. Drive your machine easily, especially in repetitive tasks and tight spaces.

### AUTOMATIC AIR CONDITIONING

Day and night, whatever the weather, set your preferred temperature for the best working conditions. Fully automatic climate control system adjusts air temperature and fan speed to maintain your ideal climate setting.

### ADJUSTABLE STEERING COLUMN

Enhance your driving comfort, and work without fatigue, by easily adjusting the steering column's tilt and telescopic movements to fit your preferred position.

### COLOUR LCD MONITOR PANEL

The 5.7" LCD panel is suitable for day and night work. The user-friendly monitor has two customisable screen displays (per operator's preference), giving full access to machine settings and maintenance data. Any abnormality is clearly displayed on the screen, allowing you to work safely and confidently with an accurate overview of all conditions.

\*Functions may not be applied to all models. Please contact your sales representative for more information on this feature.



# EASY AND SIMPLE MAINTENANCE

## "EXCELLENT SERVICE ACCESSIBILITY"

Short maintenance operations at long intervals mean you can depend on your equipment being available on-site when it's needed. Our machines are designed for simple routine maintenance, while skilled DEVELON technicians are available to provide extra support when you need it. To get the most out of your machine, you can choose the package you need from a broad range of service agreements. Uptime, productivity and residual value are all maximized, making these wheel loaders an economical and rewarding choice.



Battery cut-off switch



Centrifugal pre-cleaner  
Top Spin™ Donaldson® series



Easy maintenance access



Wheel chocks

\* The above image may differ from the actual product.





### MAINTENANCE ACCESS MADE SIMPLE

- The front and rear of the radiator – which is made of aluminium for the highest pressure resistance and a long lifetime – are easily accessible
- Air enters through the sides and top. Swing doors provide easy access for maintenance
- A battery cut-off switch makes it easy to disconnect the battery during long-term storage
- The hour meter display can be easily checked without turning the engine on

### TRIPLE-ELEMENT AIR FILTER

The forced-air cleaner removes 99% of particles and is backed up by a turbo pre-filter. Cleaning and cartridge replacement are only needed at long intervals.

### ENGINE

The DEVELON EMS (Engine Management System) uses a CAN (Controller Area Network) to provide a constant flow of operating information as well as diagnostic and ECU programming functions.

### GLOBAL DEVELON NETWORK

With a network of DEVELON Dealers & Parts Distribution Centers worldwide, your DEVELON wheel loader can be serviced & maintained wherever you are. Our service center in the heart of Europe has more than 40,000 parts in stock to supply you with top-quality components as quickly as possible.

### REVERSING 90° SWING FAN

The fan is located behind the radiator, and air is sucked in from the sides, not from behind the machine. Easier cleaning access to one-block radiator from the rear and the front. The operator can easily set standard intervals for fan reverse from the LCD display. Performance is regulated for lower fuel consumption and shorter warm-up periods.

### FULL SOLUTION PROVIDER

- The DEVELON Telematic system is available as standard – offering you all of the features for reading out vehicle operating & production parameters remotely, and providing you with total ease-of-mind
- Protection+ : an extended warranty covering parts, travel and service (check with your local dealer)
- Maintenance contract: your dealer will support you with routine service at regular intervals
- Genuine parts : manufactured and tested to ensure they always meet the same high quality standards as the original components



# MAXIMUM SAFETY AND CONTROLLABILITY

## SAFE OPERATION IN ALL SIMPLICITY

Power alone is not enough – for maximum efficiency, it needs to be matched by precise control. Our unique range of features allows every operator to get the most out of these impressive machines. Safety is crucial to your company and your employees – so, these machines feature large platforms, hand-rails, and 2 emergency exits, with maintenance performed from the ground.



Electric joystick steering



Fingertip levers

## ERGONOMIC CONTROLS

All controls are placed within the operator's easy reach. Clearly positioned for comfortable access, and grouped by function, they enable safe, confident operation. The bucket is controlled by using a convenient joystick or with fingertip levers. Both include an FNR reversing switch and kick-down function.



### REAR-VIEW CAMERA (OPTIONAL)

A camera provides a clear view of what's happening behind the machine for added safety and peace of mind. The full color display screen in the cab shows the operator what the camera sees. The panoramic view shows trucks coming up behind the loader or people on the ground, and some indicators provide a good perception of distances.

### EXTERNAL MIRRORS

The external mirrors are heated to ensure visibility and prevent accidents in cold weather.

### FULL FENDERS

To keep them clean and avoid mud splashing on the windows or accidents on slippery steps, DEVELON's wheel loaders are standard equipped with full fenders and mud guards.

### CAB

To ensure a healthy work environment, the cab air is filtered twice to eliminate all particles larger than 2 microns. Plus, the cab satisfies ROPS/FOPS regulations – a wide emergency exit (located on the right side) provides fast, easy evacuation in a critical situation.

### SAFE MAINTENANCE

Daily checking of all gauges takes place from the ground, to keep maintenance quick and safe for everyone. DEVELON has also installed an automatic greasing system (as standard) to reduce working time and increase operating comfort.



### SAFE ACCESS

To facilitate access and mobility on the machine, multiple hand-rails ensure that the operator always has a firm support to hold on to.

### DRIVING ASSISTANCE

- Automatic transmission with smooth shift transition
- Automatic transmission kick-down
- Automatic Hydraulic Differential Lock (HDL)
- Automatic Load Isolation System (LIS)
- Automatic kick-out function on lift arm
- Automatic return to dig position
- Automatic reversing fan
- Automatic greasing system





# DEVELON FLEET MANAGEMENT Telematics Service (OPTIONAL)

**TELECOMMUNICATIONS** Data flow from machine to web



## TELEMATICS TERMINAL

Terminal device is installed and connected to a machine to get machine data.



## TELECOMMUNICATION

DEVELON provides Dual mode (Cellular, Satellite) communication to maximize communication coverage



## DEVELON FM WEB

User can monitor machine status from DEVELON FM Web

**TELEMATICS SERVICE BENEFITS** DEVELON and dealer support customers to improve work efficiency with timely and responsive services

### CUSTOMER

Improve work efficiency

- Timely and preventive service
- Improve operator's skills by comparing work pattern
- Manage fleet more effectively

### DEALER

Better service for customers

- Provide better quality of service
- Maintain machine value
- Better understanding of market needs

### DEVELON

Responsive to customer's voice

- Utilize quality-related field data
- Apply customer's usage profile to develop new machine

**FUNCTIONS(WEB/APP)** DEVELON Telematics Service provides various functions to support your great performance



· GPS



· Fuel information



· Preventive maintenance



· Operation hours



· Fault code/warning



· ADT Productivity

Event Report

Start Date	End Date	Location	Model	Serial No.	Category	Event	Work No.
2015/01/01	2015/01/31	Site A	EX-300	1234567	Operation	Work Cycle	100
2015/01/01	2015/01/31	Site B	EX-300	1234567	Maintenance	Oil Change	1

· Reports

	FUNCTION	EXCAVATOR	WHEEL LOADER	ADT
GPS	Location Geo-fence	All models	All models	All models
Operation hours	Daily, Weekly, Monthly report	All models	All models	All models
Operation hours	Total operation hours Operation hours by mode	All models	All models	All models
Maintenance parts	Preventive maintenance by item replacement cycle	All models	All models	All models
Fault code/ Warning	Fault code Machine Warnings on Gauge Panel	All models	All models	All models
Fuel information	Fuel level Fuel consumption	All models	All models	All models
Dump capacity	Dump tonnage Count of Work Cycle	N/A	N/A	All models



# GLOBAL PARTS NETWORK

## QUALITY-PROVEN MAIN COMPONENTS

DEVELON provides fast and precise worldwide delivery of genuine DEVELON parts through its global PDC (parts distribution center) network.







### GLOBAL NETWORK

The global network of the GPDC (Global Parts Distribution Center) maximizes its fill rate by making sure that each center is stockpiled with all the critical parts required for businesses in its area. The network also minimizes the time and costs required for parts delivery by positioning PDCs close to major markets around the world. DEVELON PDCs communicate with customers in their time zone, informing them that they are open for operation, and deliver parts to them as early as possible.

### THE GLOBAL PARTS DISTRIBUTION CENTER NETWORK

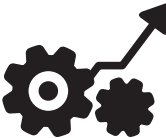
PDCs had been set up as shown below, including Mother PDC in Ansan, Korea. The ten other PDCs include one in China (Yantai), three in USA (Atlanta, Seattle and Miami), two in Europe (Germany and the UK), one in the Middle East (Dubai) and two in Asia (Singapore and Indonesia) and one in Brazil (São Paulo).



<b>PDC BENEFIT</b>					
	<b>Distribution Cost Reduction</b>	<b>Maximum Parts Fill rate</b>	<b>Shortest Distance/ Time Parts Delivery</b>	<b>Real-time Service Support</b>	<b>Minimum Downtime</b>



# TECHNICAL SPECIFICATIONS

## ENGINE

XPI direct injection (Extra high Pressure Injection) ensures high-quality fuel efficiency. Variable Geometry Turbocharger (VGT) delivers high power and strong torque, even at low idle.

### Model

Scania DC13

### No. of cylinders

6

### Nominal power - Gross (SAE J1995)

394 HP (294 kW) at 2100 rpm

### Maximum torque - Gross

2157 Nm at 1200 rpm

### Engine speed (auto-idle - idle - high)

750 - 950 - 2200 rpm [+/- 20]

### Displacement

12.7 L

### Bore x stroke

130 mm x 160 mm

### Starter

24 V - 6 kW

### Batteries - Alternator

2 x 12 V, 200 Ah - 28 V, 100 Ah

### Air filter

Centrifugal pre-cleaner Top Spin™ Donaldson® with 2-stage dry filter.

### Cooling

Cooling package with automatic reversing fan to facilitate radiator cleaning. Automatic rotation speed adjustment according to temperature conditions.

## AXLES

Front & rear axles manufactured by ZF with outboard planetary reduction gears. The front is equipped with Hydraulic Differential Lock (HDL), which means the machine has the best traction with little rolling resistance. 31 t traction power allows operation on slopes of 30°.

### Tire size - standard

29.5 R25 (L5), 29.5 R25 (L3)

### HDL lock ratio

100% (Front)

### Oscillation angle

+/- 10°

## TRANSMISSION

Powershift transmission with 3 operating modes: manual, fully automatic or semi-automatic with "kick-down" function. Based on high-quality components. Equipped with a modulation system for protection and smooth gear and direction changes. A manual transmission control lever is located to the left of the steering wheel. Direction change function is also available in automatic or semi-automatic mode. Transmission can be disengaged by the brake pedal to deliver full engine power to the hydraulics system. A safety device prevents the engine from starting if the transmission is not in neutral. Torque converter lock-up function from 2nd to 4th gear. Transmission testing and adjustment equipment are available.

### Type

4 Gear Without Lock-up

### Torque converter

Simple stage / mono phase / fixed wheel stator

### Speeds - Forward 1-2-3-4-5

6 - 12 - 19 - 26 - 37 km/h

### Speeds - Reverse 1-2-3

6 - 12 - 26 km/h

### Maximum traction

31t

### Maximum gradeability

58% / 30°

## HYDRAULIC SYSTEM

### Type

Load sensing - closed center hydraulic system

### Main pump

Dual variable displacement axial pistons pumps

### Maximum flow

480 l/min

### Maximum pressure

315 bar

### Pilot system

Automatic functions for positioning the bucket ready to dig and a function for stopping the lift arm at the desired height, and low position adjusted manually by switch, are standard.

### Filtration

In the oil return to the tank, the fiber glass filter has a filtering capability of 10 micron.



## LIFT ARM

Z-kinematics with simple lifting piston system designed for heavy-duty applications. 247 kN breakout force combines with a bucket angle that is maintained throughout the range of movement. Bucket angles are optimized in the travelling position and at ground level. Load Isolation System (LIS) is fitted as standard for improved operator comfort, output and lifetime.

### Load cycle

Lift arm - up	6.6 s	Bucket - crowd	1.2 s
Lift arm - down	4.6 s	Bucket - dump	1.2 s

### Hydraulic cylinders

	Quantity	Bore x rod diameter x stroke (mm)
Lift	2	190 x 105 x 890
Bucket	1	220 x 130 x 610

## BRAKES

Dual multi-disc circuit with sintered metal discs for extended service life. Braking system activated by a pump and accumulator circuits. Spring applied, hydraulically released parking brake is mounted on the transmission shaft and accumulator circuits and is electronically activated. Brake type: spring-applied / hydraulically released. Brake pump with variable displacement axial pistons provide 60 l/min. Operator can activate/deactivate the Clutch Cut Off on the brake pedal from a switch and can adjust the sensor proximity with the same switch. The emergency brakes are composed of a double system continually under pressure by accumulators.

### Braking distance

11.0 m at 32.4 km/h

### Number of disc brakes per wheel (front / rear)

7 / 7

### Accumulators

0.75 l - 30 bar

## FLUID CAPACITIES

Fuel tank	441 l
Urea (AdBlue®) tank	60 l
Cooling system	58 l
Engine oil	45 l
Front axle	62.5 l
Rear axle	64 l
Hydraulic tank	242 l
Transmission oil	67 l

## STEERING SYSTEM

Type	Load sensing with amplification stage and priority valve
Steering angle	40°
Oil flow	270 l/min
Operating pressure	200 bar
Steering cylinders (2)	Emergency steering system with electric motor-driven hydraulic pump.
Bore x rod diameter x stroke	120 x 70 x 465

## CAB

Safety compliance with Roll Over Protection System (ROPS) and Falling Object Protective Structure (FOPS) requirements. Spacious modular cab with excellent all-round visibility and ample storage space. Good overview of the bucket, tires and loading area thanks to wide windows. Push-button controlled air conditioning and heating with air recirculation function. Double cab air filter installed in the cab with extra protection for the operator in dusty or polluted environments. Viscous suspension mount for maximum comfort. Adjustable high-quality heated seat with air suspension, arm rests and height and tilt adjustable steering column. All operating information clearly displayed in front of the operator. Control functions are centralized on a console on the right.

### Safety standards

ROPS ISO 3471:2008 / FOPS ISO 3449

### Door

1

### Emergency exits

2

### Noise emissions

A weighted emission sound	Declared: 72 dB(A)
pressure level at the operator position (ISO 6396)	Measured: 71 dB(A)
A weighted emission sound	Declared: 107 dB(A)
power level at external position (ISO 6395)	Measured: 106 dB(A)

## PRESSURE SETTINGS

Working (pump cut-off )	275 ± 10 bar
Steering relief – LS port side	185 ± 5 bar
Steering relief – steering pump side	200 ± 5 bar
Pilot control	30 + 2 bar
Brake accumulator charging	100 ~ 160 bar
Service brake	80 ± 3 bar
Fan motor	155 ± 10 bar
Parking brake release	120 ± 5 bar
Transmission selection pressure	17 ± 1 bar



# OPERATIONAL DATA AND DIMENSIONS

DL580-5 - Pin-on		General Purpose Configurations				Rehandling Configurations			
Bucket	m <sup>3</sup>	5.0 Tooth	5.2 Cutting Edge	5.7 Segment Edge	5.7 Cutting Edge	5.8 Cutting Edge	5.8 Segment Edge	6.4 Cutting Edge	6.4 Segment Edge
Tire		29.5R 25(L5)	29.5R 25(L5)	29.5R 25(L3)	29.5R 25(L5)	29.5R 25(L5)	29.5R 25(L5)	29.5R 25(L5)	29.5R 25(L5)
Counterweight	kg	3,970	3,970	3,970	3,970	3,970	3,970	3,970	3,970
Capacity heaped ISO/SAE	m <sup>3</sup>	5.0	5.2	5.7	5.7	5.8	5.8	6.4	6.4
<b>B</b> Bucket width	mm	3,405	3,405	3,404	3,405	3,424	3,424	3,424	3,424
Breakout force	kN	270	252	231	233	201	201	190	190
Static tipping load(straight)	kg	30,621	30,244	29,011	29,838	28,600	28,563	28,604	28,566
Static tipping load(at full turn)	kg	27,039	26,706	25,617	26,347	25,254	25,222	25,258	25,225
<b>H</b> Dump height (at 45deg - fully raised)*	mm	3,340	3,500	3,405	3,420	3,275	3,120	3,215	3,055
<b>I</b> Dump reach (at 45deg - fully raised)*	mm	1,465	1,325	1,420	1,400	1,545	1,685	1,610	1,750
Digging depth	mm	60	50	80	50	50	60	50	60
<b>J</b> Height at bucket pivot point	mm	4,815	4,815	4,796	4,815	4,815	4,815	4,815	4,815
Max. tilt angle in carry position	°	48	48	48	48	48	48	48	48
<b>M</b> Max. tilt angle fully raised	°	67	67	67	67	67	67	67	66
<b>K</b> Max. tilt angle on ground	°	43	43	43	43	43	43	43	43
Max. tilt angle at max reach	°	67	67	67	67	67	67	67	67
Max. dump angle at max reach	°	68	68	68	68	68	68	68	68
Max. dump angle on ground	°	81	81	81	81	81	81	81	81
<b>L</b> Max. dump angle fully raised	°	46	46	46	46	46	46	46	46
<b>O</b> External radius at tire side	mm	7,055	7,055	7,055	7,055	7,055	7,055	7,055	7,055
<b>Q</b> External radius at bucket edge	mm	7,540	7,475	7,570	7,505	7,575	7,640	7,600	7,670
<b>E</b> Wheel base	mm	3,700	3,700	3,700	3,700	3,700	3,700	3,700	3,700
<b>D</b> Width at tires	mm	3,186	3,186	3,170	3,186	3,186	3,186	3,186	3,186
<b>F</b> Tread	mm	2,420	2,420	2,420	2,420	2,420	2,420	2,420	2,420
<b>G</b> Ground clearance(at 12deg osc.)	mm	480	480	480	480	480	480	480	480
<b>A</b> Overall length	mm	9,855	9,645	10,150	9,755	9,960	10,170	10,050	10,260
<b>C</b> Overall height	mm	3,785	3,785	3,785	3,785	3,785	3,785	3,785	3,785
Operating weight	kg	34,835	34,974	33,891	35,103	35,532	35,558	35,677	35,703

		29.5 R25 - L3	29.5 R25 - L4	29.5 R25 - L5
Width at tires edge - Empty	mm	-4	-2	3186
Width at tires edge - Loaded	mm	-9	-11	3266
<b>C</b> Overall height	mm	-30	-10	Base
<b>G</b> Ground clearance (at 12° osc.)	mm	-30	-10	Base
<b>J</b> Height at bucket pivot point	mm	-30	-10	Base
Static tipping load (straight)	kg	-995	-570	Base
Static tipping load (at full turn)	kg	-878	-503	Base
Operating weight	kg	-1397	-758	Base



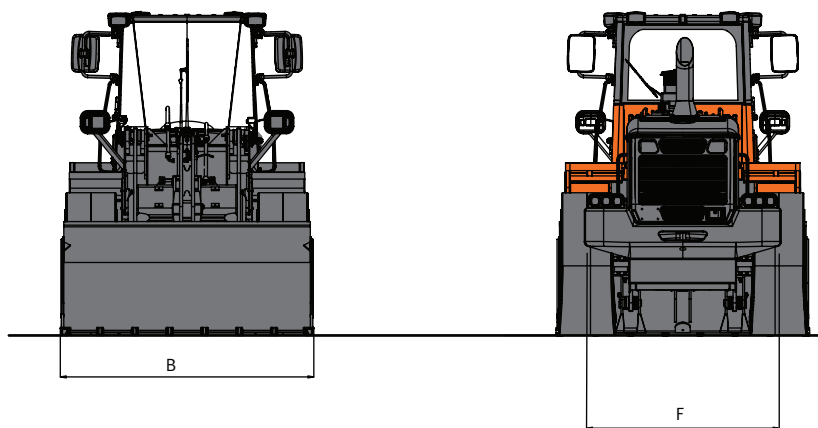
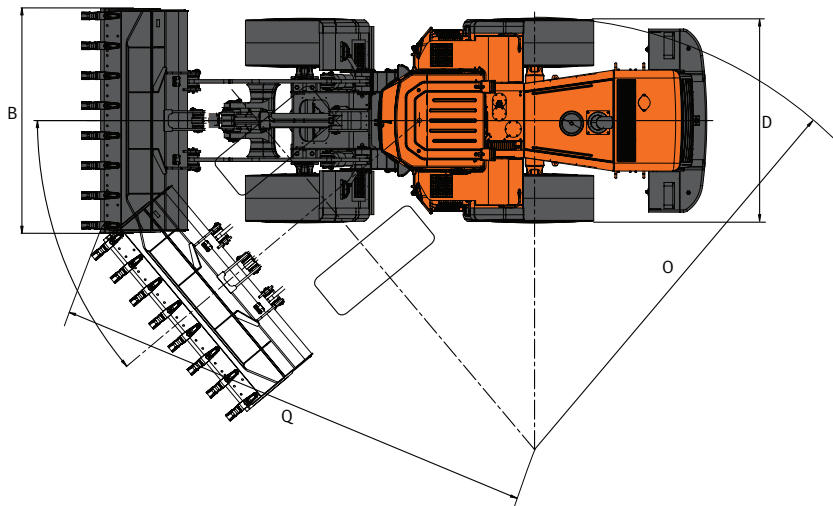
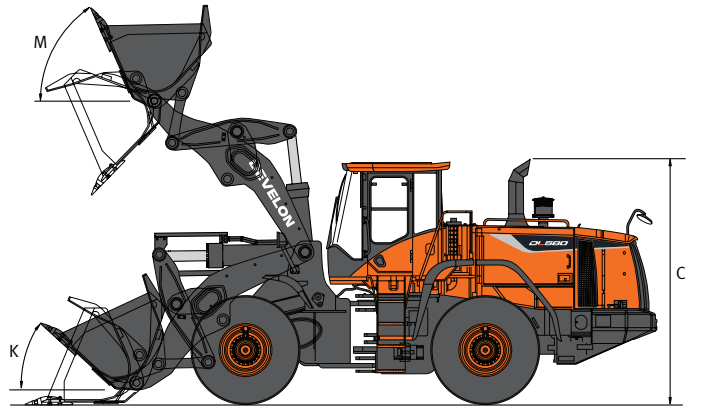
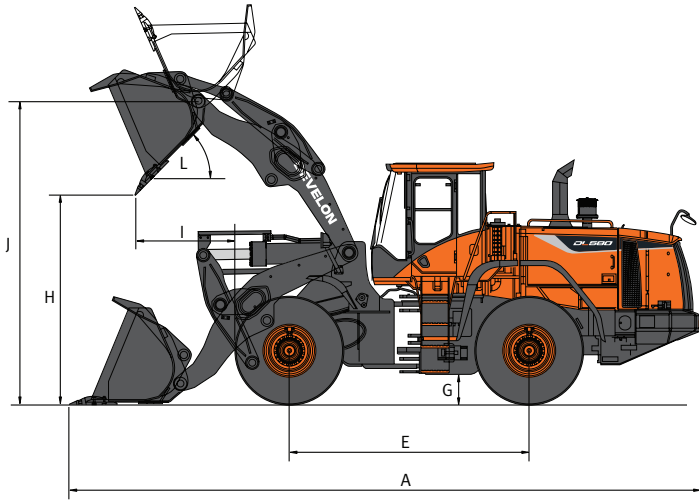



# STANDARD AND OPTIONAL EQUIPMENT

## STANDARD EQUIPMENT

### Performances

---

- Scania, Tier 2/3 compliant, SCR, EGR, DOC, water-cooled, diesel engine with Variable Turbo Charger and air-to-air intercooler
- Engine power mode selector switch (Standard / Economy & Power mode)
- Power-up pedal function by full stroke of acceleration
- Auto shut-off engine
- Fuel heater
- Transmission clutch cut-off via the brake pedal
- Transmission mode selector switch (Manual / Auto 1 ↔ 4 / Auto 2 ↔ 4 with kick-down)
- Hydraulic load sensing system, variable displacement pump
- Hydraulic lock differential on front
- Counterweight
- Robust Z bar lifting system

### Maintenance

---

- Self-diagnosis system & monitoring indicator by the dashboard, plus electronic plug for fast adjustment
- Fast couplers for hydraulic check
- External drains for engine oil and coolant changes

### Comfort

---

- Automatic lift arm kick-out
- Automatic return to dig
- Levelling function
- Automatic air conditioning with electronic climate control
- Adjustable steering column (tiltable & telescopic)
- Tinted safety glass
- Left sliding window
- Right opening window (180°)
- Floor mat
- Multiple storage compartments
- Cup holder
- Loud speakers and connections for radio
- Lift arm float kick-out
- Alternator 28 V / 100 Ah
- Dashboard monitoring with LCD display (dials, gauges and lamps)
- Interior cab light
- Cigarette lighter and 12 & 24 Volt power sockets

### Safety

---

- Emergency steering pump driven by electric motor
- Full fenders with rubber protection
- ROPS cab (SAE J 394, SAE 1040, ISO 3471)
- FOPS cab (SAE J 231, ISO 3449)
- Double filtered air cab
- Right opening window (emergency exit)
- Front and rear wiper and washer
- Retractable roller sun visor front & rear
- Road lights: low and high beam, tail indicators, stop, reversing lights
- Work lights: 2 halogen at the front and 4 at the rear (6 x 70 W)
- Reverse travel alarm
- Rotating beacon
- Horn
- Heated external mirrors
- Interior rear view mirrors
- Anti-slip steps & platforms
- Starting safety system
- Brake circuits with accumulator
- Dual service brake pedals
- Electric parking brake on the transmission, spring-applied hydraulic release
- Wheel chocks
- Handrail on top of the cab and anti-slip platforms on front frame

### Other

---

- Bottom protection plates
- Tie hooks
- Articulation lock in the transport position
- Towing hitch
- Tires 29.5 R25 (L5)
- Automatic lubrication system
- Hydraulic reversing engine fan
- "DEVELON Connect" Telematic system



## OPTIONAL EQUIPMENT

### Performances

---

- Additional counterweight
- Wide range of buckets
- Torque converter lock-up
- Axle oil cooling system

### Maintenance

---

- Bio oil
- 3-year or 5-year warranty
- Protection+ warranty

### Comfort

---

- Grammer air-suspension seat with safety belt 3 points
- Fingertip levers
- Weighing system
- Load isolation system (LIS)
- 3rd hydraulic function
- Grammer air-suspension seat with safety belt 2 points
- Electric joystick steering on armrest
- Joystick lever with FNR and thumbwheel roller

### Other

---

- Tyres 29.5 R25 (L3)



# We are **DEVELON**

We trace our roots to 1937 as one of Korea's first large scale machine plant. Throughout time we have consistently delivered exceptional products and solutions.

DEVELON is a bold name that reflects our core ambition to continue developing onwards and leaving behind a positive footprint in our world. Moving forward, we seek to be part of our customers and partners' endeavor to build a better world.

## Powered by **Innovation**



©2024 HD Hyundai Infracore. All rights reserved.  
**HDIPBE-01-2401**

Certain specification(s) are based on engineering calculations and are not actual measurements. Specification(s) are provided for comparison purposes only and are subject to change without notice. Specification(s) for your individual Develon equipment will vary based on normal variations in design, manufacturing, operating conditions, and other factors. Pictures of Develon units may show other than standard equipment

**[develon-ce.com](https://develon-ce.com)**

