

DOOSAN

Construction Equipment

DL550-5 Block handler

Engine Power	SAE J1995, gross 283 kW (380 hp) @ 1,800 rpm
Operational Weight	36,030 kg (79,433 lb)



THE NEW DL550-5 BLOCK HANDLER MEETS SPECIAL REQUIREMENTS IN HARSH APPLICATION

DL 550-5
BLOCK HANDLER

THE DL550-5 BLOCK HANDLER IS DESIGNED TO WITHSTAND THE DEMANDING AND HARSH ENVIRONMENT OF BLOCK HANDLING APPLICATIONS
THE DL550-5 BLOCK HANDLER DELIVERS GOOD ENOUGH POWER AND RELIABILITY TO MEET YOUR BLOCK HANDLING NEEDS

PERFORMANCE

Thanks to their robust design and the use of high-quality components, the Doosan wheel loaders deliver very high performance – ensuring the best productivity and reliability.

HEAVY DUTY DESIGN

With the Block handler specification this basic machine is adapted to special requirements in this application.

IMPROVED ERGONOMICS:

More space, better visibility, high comfortable features, and plenty of storage space make it easy to work for hours.





TOP FUEL EFFICIENCY & PRODUCTIVITY

DL550-5 BLOCK HANDLER

STRENGTH AND INTELLIGENCE – A WINNING COMBINATION!

Exceptional power – combined with the finest workmanship

- Impressive breakout force and high traction make tilt-up easy and allow you to tackle the hardest materials
- Enhanced steering unit & cylinder makes work quick and efficient
- New Scania DC13 engine with SCR technology provides the power you need while meeting Stage IV environmental regulations



NEW ENGINE – LOWER EMISSIONS / HIGHER TORQUE

The DL550-5 Block Handler is equipped with Scania engines. Renowned for excellent fuel efficiency, reliability and long service life, they combine exceptional power output with high torque at low revs. For faster machine response – even at very low speed – XPI (extra-high pressure injection) common-rail fuel injection (2400 bar) is combined with a Variable Geometry Turbocharger (VGT). Selective Catalytic Reduction (SCR) technology, combined with a Diesel Oxidation Catalyst (DOC), ensures compliance with Stage IV environmental regulations. As there is no need for a particulate filter, there is no need for regeneration.



LOCK-UP

The DL550-5 Block handler also feature torque converter lockup. When this is activated, the engine automatically connects directly to the transmission (depending on speed and travel resistance), even from 2nd gear. The transmission receives the full engine power without hydraulic slip – thus increasing speed on slope dramatically. This feature can save you up to 10% in fuel costs.

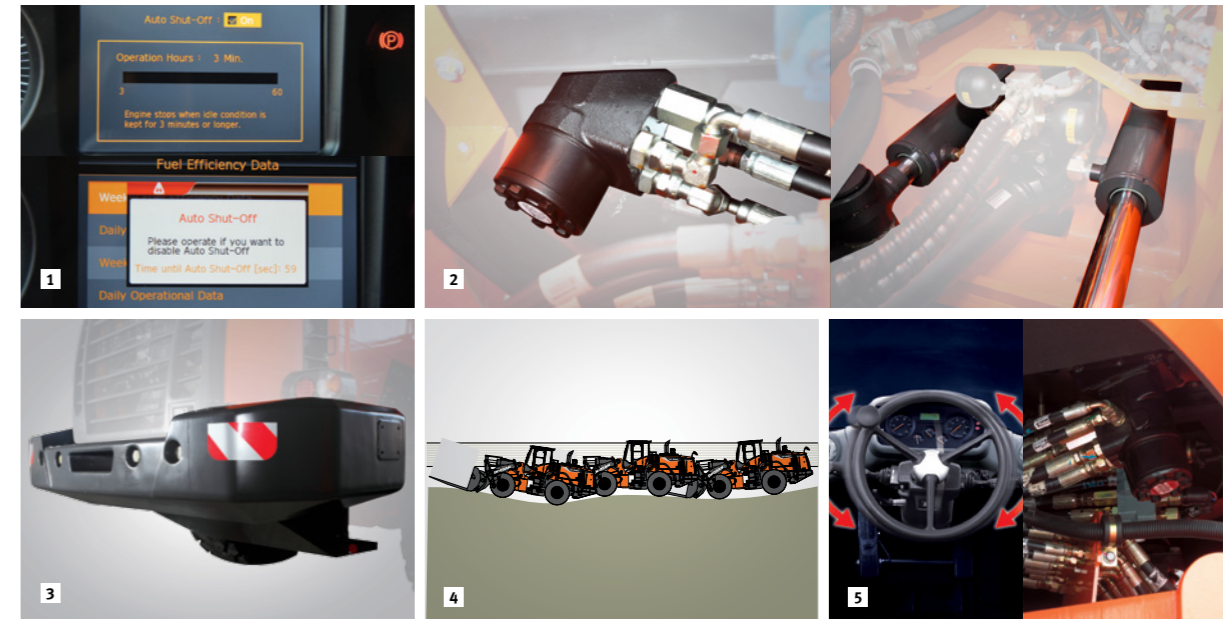
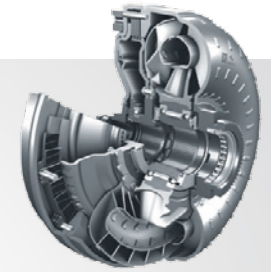

1 SAVE FUEL, SAVE MONEY

To improve your fuel efficiency, an auto shut-down reduces the idle time of the engine, to prevent the over-consumption and useless operating hours. You can easily set the auto shut-down (to stop the engine after 3 to 60 minutes) via the LCD display.

2 LARGER STEERING CYLINDERS AND UNIT FOR BLOCK HANDLER

DL550-5 Block handler is equipped with larger steering unit and cylinders on the linkage that help improve load control and ensure safe and long lasting operation.

3 HEAVIER COUNTERWEIGHT FOR BLOCK HANDLER

To improve stability, DL550-5 block handler is equipped with heavier counterweight. The Block handler adds 1,950kg of counterweight.

- DL550-5 Block handler counterweight : 3,970kg

4 LOAD ISOLATION SYSTEM

This system is ideal for all loading and movement situations and increases driver productivity and comfort. It also minimises the amount of material spilt during travelling.

5 HYDRAULIC POWER STEERING

The newly designed steering system ensures smooth steering even in the low engine speed ranges.
- Steering control valve

LOAD SENSING HYDRAULIC CLOSED CENTRE SYSTEM

This system provides maximum hydraulic performance, without producing excess capacity, thus saving fuel and extending the lifetime and reliability of vital components (such as the pumps and the main control valves).





RELIABILITY, THE HABIT OF A LIFETIME

DL550-5 BLOCK HANDLER

DESIGNED SOLID AND TOUGH.

Reinforced axles in combination with the axle oil cooler device result in a package which meets all block handling application needs.



HEAVY DUTY AXLE FOR BLOCK HANDLER

Even hard working condition heavy duty axle delivers the best reliability to customer. Increased brake discs and hub parts give better reliability and cooling efficiency. Heavy duty axle is strong in long hour operation.



HEAVY DUTY FRONT FOR BLOCK HANDLER

The heavy duty front provides a special design of lift arm pin point to improve cycle time. Also increased Lift cylinder stroke gives larger lifting capacity and durability.

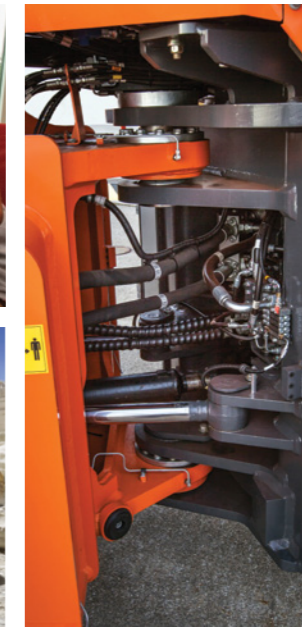

DESIGNED TO LAST

We pay the closest attention to the design and manufacture of structural components. Finite Element Analysis is used to ensure an extended lifetime for main structures such as the chassis, joints and lift arm. Then, after modelling, they are subjected to intensive laboratory and field testing in extreme conditions. Ongoing statistical analysis is used to continually increase reliability.

DURABLE STEEL PARTS

Rear parts – such as the radiator grille, engine bonnet and fenders – are made of solid steel. They're also designed for easy repair, reducing the need to replace them if they are damaged.

AUTOMATIC HYDRAULIC DIFFERENTIAL LOCKS

Hydraulic differential locks on the front and rear automatically engage to ensure maximum tractive effort with a lock of 100% and an easy driving. Muddy and slippery areas can be anticipate by the operator with the manual foot control. They also reduce the risk of skidding and prevent excessive tyre wear. The brake discs in the planetary reduction gears are reinforced, ensuring long hours of operation and easy maintenance access. Automatic Limited Slip Differential lock is also available on the DL550-5 model.

EXHAUST

The inner exhaust pipe sucks air out of the engine compartment through an outer pipe – this "chimney" effect provides constant air circulation and prevents deposits of flammable material on hot parts.

AUTO-LUBE SYSTEM (OPTIONAL)

DL550-5 Block handler can be equipped with an automatic central greasing system: 'Auto-lube' protects components for longer machine lifetime.

ORFS (O-RING FACE SEAL)

All hydraulic lines, even the low pressure circuits, are sealed with ORFS couplings to prevent leaks.

AXLES COOLING SYSTEM FOR BLOCK HANDLER

To ensure you the maximum performances from your machine, even in very hard applications, axles could be equipped with an oil cooling system and thus ensure proper operation in any conditions.

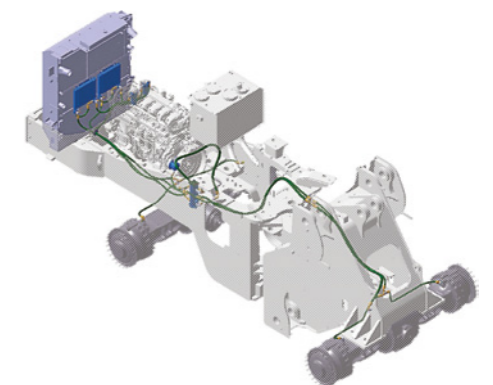



OPERATING IN COMFORT

DL550-5 BLOCK HANDLER



- 1. Radio
- 2. Climate control HVAC
- 3. Storage compartment for sunglasses & sun visor
- 4. Colour rear-view camera
- 5. Opening emergency exit
- 6. Joystick or fingertip control
- 7. Large control armrest
- 8. Improved visibility on the bottom left & right
- 9. Colour LCD monitor panel
- 10. Multi-settings high-comfort air-suspension seat with joystick steering
- 11. Large storage compartments
- 12. Emergency engine stop switch
- 13. Large ergonomic pedals
- 14. Differential lock pedal
- 15. Flat, spacious, easy-to-clean floor
- 16. Extinguisher location
- 17. Fuse box

The productivity of your wheel loader is directly linked to the operator's performance. That's why Doosan has placed comfort at the very centre of its design priorities for the DL550-5. More space, better visibility, a high comfortable seat, and plenty of storage space make it easy to work for hours without fatigue or discomfort. And there's no need to pay extra for the options you want – most of them are standard features on this loader!

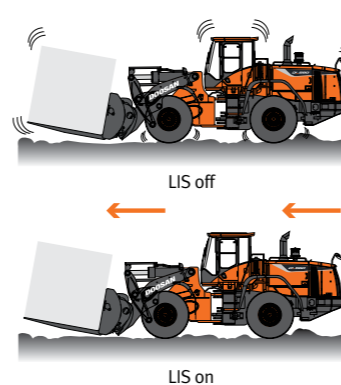

OPERATOR ENVIRONMENT

A modern and attractive work space offers generous headroom, and seat movement provides lots of leg room. Interior materials are selected for their high quality and easy cleaning. In addition, your belongings are right at hand, thanks to several storage boxes throughout the cab.

COMFORTABLE AUTOMATIC LIFT ARM

Save time and reduce the number of operations with the "lift arm raise kick-out" and "return to dig" system. These functions are operated electronically from inside the cab.

HIGH-COMFORT AIR SUSPENSION SEAT

With vertical and horizontal suspension, the ultra-comfortable, heated and fully adjustable Grammer seat are featured as standard, giving you the feeling of being comfortably installed in your own sofa.

LOAD ISOLATION SYSTEM

This standard feature provides a smooth ride over rough ground, operator comfort, and reduced cycle times due to improved vehicle stability in movement. Higher productivity and better fuel efficiency while performing load & carry applications. Speed for automatic activation is adjustable by the operator.

ACCURATE & SMOOTH JOYSTICK STEERING

Keep your concentration and reduce strain with the comfortable joystick steering integrated on the armrest. Drive your machine easily, especially in repetitive tasks and tight spaces.

AUTOMATIC AIR CONDITIONING

Day and night, whatever the weather, set your preferred temperature for the best working conditions. Fully automatic climate control system adjusts air temperature and fan speed to maintain your ideal climate setting.

ADJUSTABLE STEERING COLUMN

Enhance your driving comfort, and work without fatigue, by easily adjusting the steering column's tilt and telescopic movements to fit your preferred position.

COLOUR LCD MONITOR PANEL

The 5.7" LCD panel is suitable for day and night work. The userfriendly monitor has two customizable screen displays (per operator's preference), giving full access to machine settings and maintenance data. Any abnormality is clearly displayed on the screen, allowing you to work safely and confidently with an accurate overview of all conditions.



EASY MAINTENANCE - SIMPLE MAINTENANCE

DL550-5 BLOCK HANDLER

"EXCELLENT SERVICE ACCESSIBILITY"

Short maintenance operations at long intervals mean you can depend on your equipment being available on-site when it's needed. Our machines are designed for simple routine maintenance, while skilled Doosan technicians are available to provide extra support when you need it. To get the most out of your machine, you can choose the package you need from a broad range of service agreements. Uptime, productivity and residual value are all maximized, making these wheel loaders an economical and rewarding choice. Building further on the success of the Stage IIIB engines, the new Stage IV Scania engine has no need for a DPF filter to meet the Stage IV emissions requirements. Which means no maintenance required – resulting in more uptime!



MAINTENANCE ACCESS MADE SIMPLE

- The radiator – which is made of aluminium for the highest pressure resistance and a long lifetime – are easily accessible
- Air enters through the sides and top. Swing doors provide easy access for maintenance
- A battery cut-off switch makes it easy to disconnect the battery during long-term storage
- The hour meter display can be easily checked without turning the engine on

TRIPLE-ELEMENT AIR FILTER

The forced-air cleaner removes 99% of particles and is backed up by a turbo pre-filter. Cleaning and cartridge replacement are only needed at long intervals.

ENGINE

The Scania EMS (Engine Management System) uses a CAN (Controller Area Network) to provide a constant flow of operating information as well as diagnostic and ECU programming functions.

UREA TANK

Connected to the ECU, sensors in the tank detect low levels of AdBlue® and any system malfunction.

REVERSING 90° SWING FAN

The fan is located behind the radiator, and air is sucked in from the sides, not from behind the machine. Easier cleaning access to one-block radiator from the rear and the front. The operator can easily set standard intervals for fan reverse from the LCD display. Performance is regulated for lower fuel consumption and shorter warm-up periods.

FULL SOLUTION PROVIDER

- The Doosan Telematic system is available as standard – offering you all of the features for reading out vehicle operating & production parameters remotely, and providing you with total ease-of-mind
- Maintenance contract: your dealer will support you with routine service at regular intervals
- Genuine parts: manufactured and tested to ensure they always meet the same high quality standards as the original components



Battery cut-off switch



Centrifugal pre-cleaner Top spin



Drains



Wheel chocks



MAXIMUM SAFETY AND CONTROLLABILITY

DL550-5
BLOCK HANDLER

SAFE OPERATION IN ALL SIMPLICITY

Power alone is not enough – for maximum efficiency, it needs to be matched by precise control. Our unique range of features allows every operator to get the most out of these impressive machines. Safety is crucial to your company and your employees – so, Doosan machines feature large platforms, hand-rails, and 2 emergency exits, with maintenance performed from the ground.

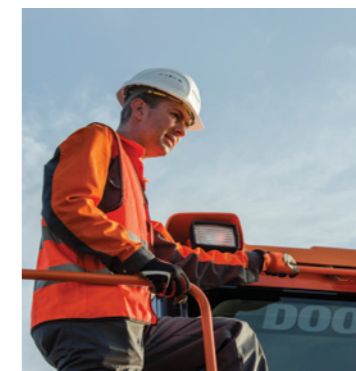

ERGONOMIC CONTROLS

All controls are placed within the operator's easy reach. Clearly positioned for comfortable access, and grouped by function, they enable safe, confident operation. The bucket is controlled by using a convenient joystick or with fingertip levers. Both include an FNR reversing switch and kick-down function.



Joystick steering (Optional)



Joystick configuration (Optional)

REAR VIEW CAMERA

A camera provides a clear view of what's happening behind the machine for added safety and peace of mind. The full colour display screen in the cabin shows the operator what the camera sees. The panoramic view shows trucks coming up behind the loader or people on the ground, and some indicators provide a good perception of distances.

EXTERNAL MIRRORS

The external mirrors are heated to ensure visibility and prevent accidents in cold weather.

FULL FENDERS (OPTIONAL)

To keep them clean and avoid mud splashing on the windows or accidents on slippery steps, Doosan's wheel loaders are standard equipped with full fenders and mud guards.

CABIN

To ensure a healthy work environment, the cab air is filtered twice to eliminate all particles larger than 2 microns. Plus, the cab satisfies ROPS/FOPS regulations – a wide emergency exit (located on the right side) provides fast, easy evacuation in a critical situation.

SAFE MAINTENANCE

All the daily gauges checking takes place from the ground, to be operate quickly and safely by everyone. Doosan has also installed an automatic greasing system (as standard) to reduce working time and increase operating comfort.

SAFE ACCESS

To facilitate access and mobility on the machine, multiple hand-rails ensure that the operator always has a firm support to hold on to.

DRIVING ASSISTANCE

- Automatic transmission with smooth shift transition
- Automatic Hydraulic Differential Lock (HDL)
- Automatic Lift-arm Suspension (LIS)
- Automatic kick-out function on lift arm
- Automatic return to dig position
- Automatic reversing fan
- Automatic greasing system (Optional)

TELECOMMUNICATIONS

Data flow from machine to web



TELEMATICS SERVICE TERMINAL

Telematics Service terminal is installed to machine / connected to EPOS™



TELECOMMUNICATION

GPS, EPOS™ data is sent to designated server by GSM, Satellite telecommunication

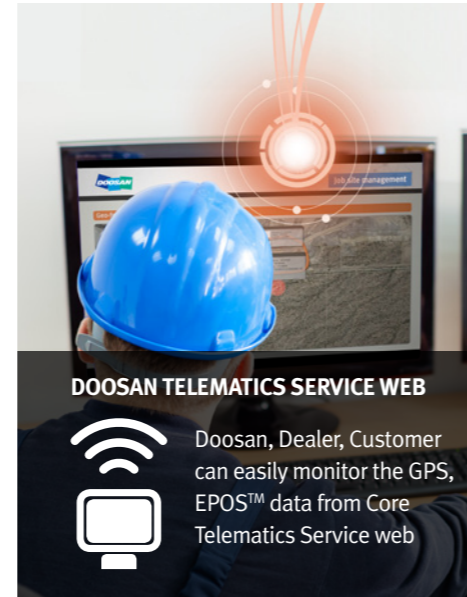

DOOSAN TELEMATICS SERVICE WEB

Doosan, Dealer, Customer can easily monitor the GPS, EPOS™ data from Core Telematics Service web

FUNCTIONS

Doosan Telematics Service provides various functions to support your great performance

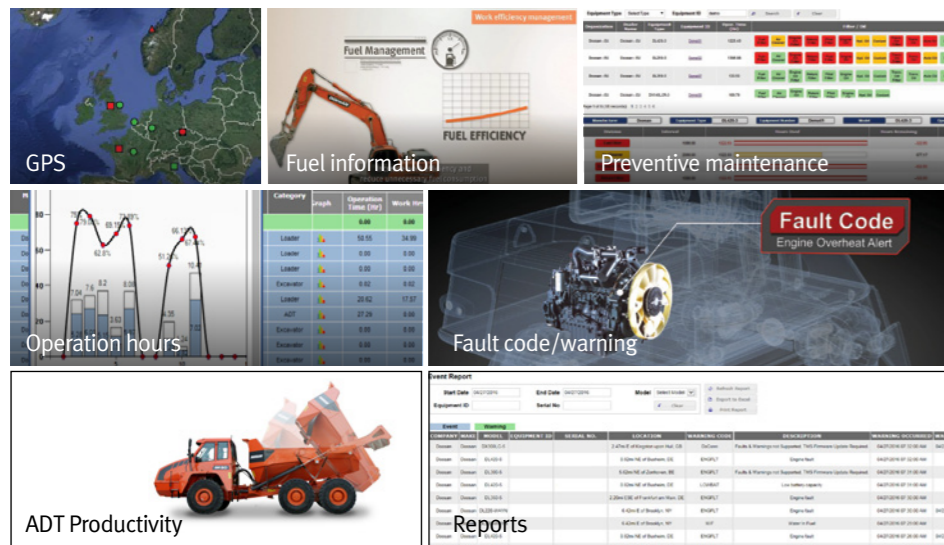

TELEMATICS SERVICE BENEFITS

Doosan and dealer support customers to improve work efficiency with timely and responsive services

Customer

- Improve work efficiency
- Timely and preventive service
- Improve operator's skills by comparing work pattern
- Manage fleet more effectively

Dealer

- Better service for customers
- Provide better quality of service
- Maintain machine value
- Better understanding of market needs

Doosan

- Responsive to customer's voice
- Utilize quality-related field data
- Apply customer's usage profile to developing new machine

GLOBAL PDC (PARTS DISTRIBUTION CENTER) NETWORK

Doosan provides fast and precise worldwide delivery of genuine Doosan parts through its global PDC (parts distribution center) network.

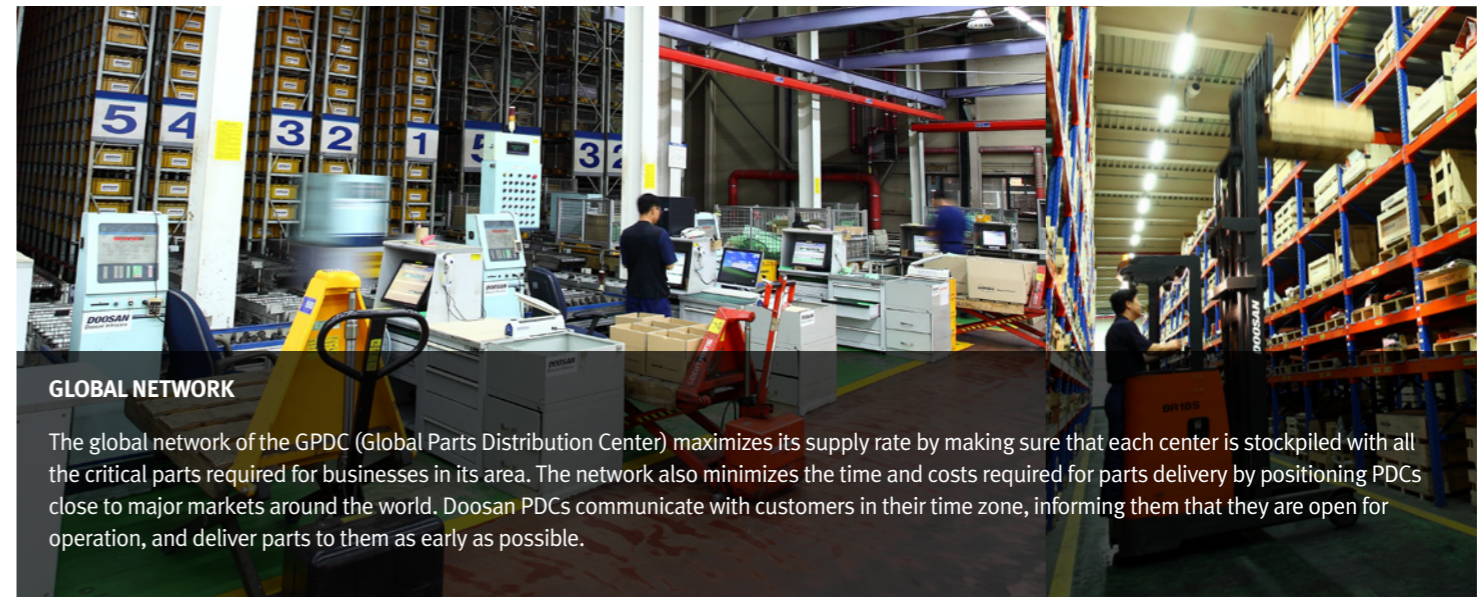

GLOBAL NETWORK

The global network of the GPDC (Global Parts Distribution Center) maximizes its supply rate by making sure that each center is stocked with all the critical parts required for businesses in its area. The network also minimizes the time and costs required for parts delivery by positioning PDCs close to major markets around the world. Doosan PDCs communicate with customers in their time zone, informing them that they are open for operation, and deliver parts to them as early as possible.

The Global Parts Distribution Center Network

PDCs had been set up as shown below, including Mother PDC in Ansan, Korea. The seven other PDCs include one in China (Yantai), one in the USA (Chicago), one in Brazil (Campinas), two in Europe (Germany and the UK), one in the Middle East (Dubai), and one in Asia (Singapore).



MPDC : Mother Parts Distribution Center PDC : Parts Distribution Center

FUNCTION	EXCAVATOR	WHEEL LOADER	ADT
GPS	Location Geo-fence	All models	All models
E-mail reports	Daily, Weekly, Monthly report	All models	All models
Operation hours	Total operation hours Operation hours by mode	All models Tier 4 only	All models
Maintenance parts	Preventive maintenance by item replacement cycle	All models	Tier 4 only
Fault code/ Warning	Fault code Machine Warnings on Gauge Panel	All models	Tier 4 only
Fuel information	Fuel level Fuel consumption	All models Tier 4 only	All models
Dump capacity	Dump tonnage Count of Work Cycle	N/A	N/A

PDC BENEFIT

- Distribution Cost Reduction
- Maximum Parts supply rate
- Shortest distance/time parts delivery
- Real-time service support
- Minimum downtime

TECHNICAL SPECIFICATIONS

ENGINE

Scania Stage IV (Tier 4 final) compliant diesel engine fully meets the latest emissions regulations.

XPI direct injection (Extra high Pressure Injection) ensures very good fuel efficiency.

Variable Geometry Turbocharger (VGT) delivers high power and strong torque, even at low idle.

Electronic engine controls optimise machine performance and manage the catalytic operations by a Diesel Oxidation Catalyst (DOC) and a Selective Catalytic Reduction (SCR)

Model	Scania DC13
Regulation compliant	Stage IV
No. of cylinders	6
Nominal power - Gross (SAE J1995)	380 hp (283 kW) @ 1.800 tr/min
Maximum torque - Gross	1765 N.m @ 1.300 rpm
Idle (low - auto idle - high)	750 - 950 - 2200 [±20] rpm
Displacement	12.7 litres
Bore x stroke	130 x 160 mm
Starter	24 V x 6 kW
Batteries - Alternator	2 x 12 V, 200 Ah - 28 V, 100 Ah
Air filter	Centrifugal pre-cleaner Turbo III with 2-stage Donaldson dry filter.
Cooling	Cooling package with automatic reversing fan to facilitate radiator cleaning. Automatic rotation speed adjustment according to temperature conditions.
AXLES	
Front & rear axles manufactured by ZF with outboard planetary reduction gears. The front and the rear are equipped with Hydraulic Differential Lock (HDL), which means the machine has the best traction with few rolling resistance. From 23.6 t to 31.0 t traction power allows operation on slopes of 51%.	
LSD lock ratio	100% (Front)
HDL lock ratio	-
Oscillation angle	+/- 10°

TRANSMISSION

5-Gear powershift transmission with 3 operating modes: manual, fully automatic or semi-automatic with ”kick-down” function.

Based on high-quality components. Equipped with a modulation system for protection and smooth gear and direction changes. A manual transmission control lever is located to the left of the steering wheel.

Direction change function also available in automatic or semi-automatic mode. Transmission can be disengaged by the brake pedal to deliver full engine power to the hydraulics system. A safety device prevents the engine from starting if the transmission is not in neutral. Torque converter lock-up function from 2nd to 5th gear. Transmission testing and adjustment equipment available.

Type	ZF 5 WG 310 + lock-up
Torque converter	Simple stage / mono phase / fixed wheel stator
Speeds - Forward 1-2-3-4-5	6.3 - 12.0 - 18.8 - 25.9 - 36.5 km/h
Speeds - Reverse 1-2-3	6.3 - 12.0 - 25.7 km/h
Maximum traction	31.0 t
Maximum gradeability	58% / 30°

HYDRAULIC SYSTEM

Type	Load sensing - closed centre hydraulic system
Main pump	Dual variable displacement axial pistons pumps
Maximum flow	480 l/min
Maximum pressure	315 bar
Pilot system	Automatic functions for positioning the bucket ready to dig and a function for stopping the lift arm at the desired height, and low position adjusted manually by switch, are standard.
Filtration	In the oil return to the tank, the fibre glass filter has a filtering capability of 10 micron.

LIFT ARM

Z-kinematics with simple lifting piston system designed for heavy-duty applications. 23.1 & 24.7 tons breakout force combined with a bucket angle that is maintained throughout the range of movement. Bucket angles are optimised in the travelling position and at ground level. Load Isolation System (LIS) is fitted as standard for improved operator comfort, output and lifetime.

Load cycle		
Lift arm - up	6.6 s	
Lift arm - down	4.6 s	
Bucket - dump	1.2 s	
Hydraulic cylinders	Quantity	Bore x rod diameter x stroke (mm)
Lift	2	190 x 105 x 890
Bucket	1	220 x 130 x 610

BRAKES

Dual multi-disc circuit with sintered metal discs for extended service life. Braking system activated by a pump and accumulator circuits. Spring-applied, hydraulically released parking brake is mounted on the transmission shaft and accumulator circuits and is electronically activated.

Brake type: spring-applied / hydraulically released.

Brake pump with variable displacement axial pistons provide 60 l/min. Operator can activate/deactivate the Clutch Cut Off on the brake pedal from a switch and can adjust the sensor proximity with the same switch. The emergency brakes are composed of a double system continually under pressure by accumulators.

Braking distance	11.0 m at 32.4 km/h
Number of disc brakes per wheel (front / rear)	7 / 7
Accumulators	0.75 l - 30 bar

FLUID CAPACITIES

Fuel tank	441 l
Urea tank	60 l
Cooling system	60 l
Engine oil	45 l
Front axle	62.5 l
Rear axle	64 l
Hydraulic tank	247 l
Transmission oil	54 l

STEERING SYSTEM

Type	Load sensing with amplification stage and priority valve
Steering angle	40°
Oil flow	270 l/min
Operating pressure	200 bar
Steering cylinders (2)	Emergency steering system with electric motordriven hydraulic pump.
Bore x rod diameter x stroke	110 x 60 x 465

CAB

Safety compliance with Roll Over Protection System (ROPS) and Falling Object Protective Structure (FOPS) requirements. Spacious modular cab with excellent all-round visibility and ample storage space. Good overview of the bucket, tyres and loading area thanks to wide windows. Pushbutton controlled air conditioning and heating with air recirculation function. Double cab air filter installed in the cab with extra protection for the operator in dusty or polluted environments. Viscous suspension mount for maximum comfort. Adjustable high-quality heated seat with air suspension, arm rests and height and tilt adjustable steering column. All operating information clearly displayed in front of the operator. Control functions are centralised on a console on the right.

Safety standards	ROPS ISO 3471:2008 / FOPS ISO 3449
Door	1
Emergency exits	2
Noise emissions	A weighted emission sound pressure level at the operator position (ISO 6396) Declared: 72 dB(A) Measured: 71 dB(A)
A weighted emission sound power level at external position (ISO 6395)	Declared: 107 dB(A) Measured: 106 dB(A)

PRESSURE SETTINGS

Working (pump cut-off)	275 ± 10 bar
Steering relief – LS port side	185 ± 5 bar
Steering relief – steering pump side	200 ± 10 bar
Pilot control	30 + 2 bar
Brake accumulator charging	100~160 bar
Service brake	80 ± 3 bar
Fan motor	155 ± 10 bar
Parking brake release	120 ± 5 bar
Transmission selection pressure	17 ± 1 bar

DIMENSIONS

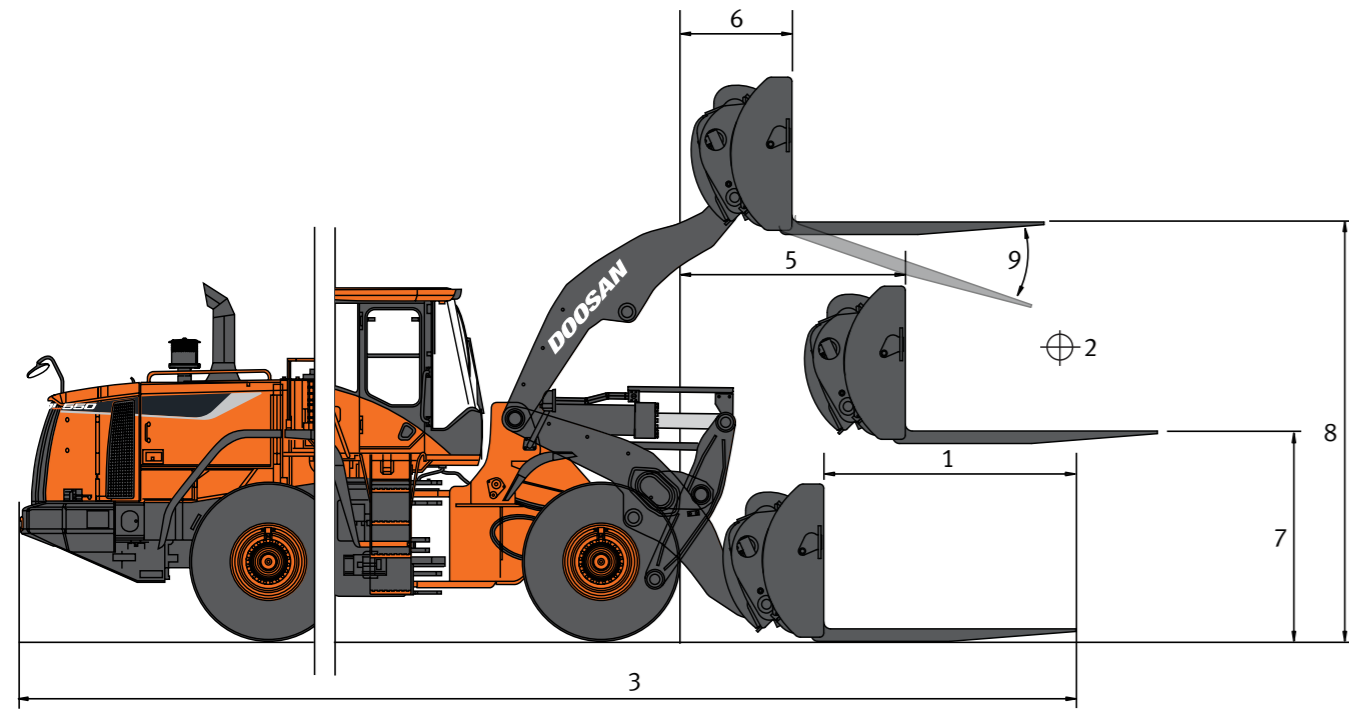

* All dimensions are approximate and it is measured by general marble fork.

Configuration			Marble fork
Fork length	1	mm	1,450
Load center	2	mm	900
Overall length	3	mm	10,070
Reach at GRD level	4	mm	1,130
Reach at max. reach	5	mm	1,945
Reach at max height	6	mm	995
Height at max reach	7	mm	2,275
Max. height	8	mm	4,585
Maximum discharge angle from horizontal	9	deg	45

ATTACHMENTS

A DOOSAN ATTACHMENT FOR OPTIMUM PERFORMANCE IN EACH ACTIVITY

Robust construction, excellent penetration, covering several types of applications from light- up to severe-duty. These new Doosan loader attachments are designed and manufactured in Europe to meet local requirements and standards. A large range of attachments guarantees versatility and efficiency all the way. Each bucket is designed for a specific machine model to fit its key kinematic parameters perfectly. Critical bucket positions are optimised to improve digging and dumping. The Doosan attachment concept stands for high quality, perfect fit and excellent operational capabilities.



GENERAL PURPOSE BUCKETS

General purpose buckets provide good all-round performance for stockpiling and material-handling operations. With its sloped bottom design for optimum bucket filling capabilities and load retention, this is the perfect bucket for day-to-day material handling. It can be equipped with optional teeth, shrouds and cutting edge, depending on the customer's requirements.



HEAVY-DUTY BUCKETS

Heavy-duty bucket suitable for a range of applications that require a robust construction (such as sand handling or occasional severe loading). Parts subjected to high stress – such as the edge, sidebars and corner protections – are made of hardened steel. Optional teeth, shrouds and reversible cutting edge allow you to tailor the bucket to the customer's needs.

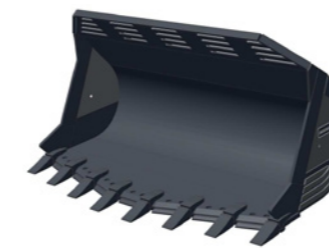

V-SHAPE ROCK BUCKETS

Used for handling and digging of hard compacted material and blasted rock in mining or quarry applications, where high break-out force is required. Severe digging is no problem for this tough bucket, made entirely of highly wearresistant steel with a hardness of 420 BHN. Weld-on ESCO® teeth come standard.

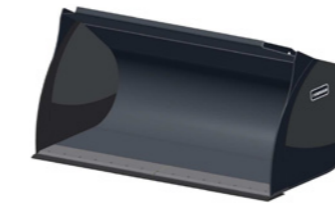

LIGHT MATERIAL BUCKETS

When you need to move large amounts of light material, this bucket is the most profitable and rewarding choice. Its convex sides allow high capacity and avoid material spilling. Comes standard with a bolted reversible cutting edge.

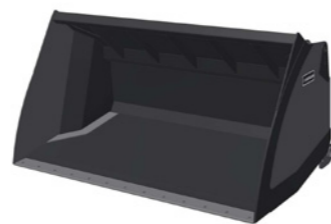

HIGH DUMP BUCKET

The high dump bucket is suitable for light material handling applications. This bucket improves the unload height and increases the versatility of the wheel loader. Its convex sides allow high capacity and avoid material spilling. Comes standard with a bolted reversible cutting edge.



BLOCK FORKS

These forks are used to handle blocks in quarry applications. Subject to heavy constraints, these forks are strengthened and well suited with the optimized Z-bar on large wheel loaders.



LOG GRABS

Log grabs are designed to handle easily and safely all kind of trunks for forestry applications. Available with different configurations, they are manufactured of hardened steel to endure high stress.



STANDARD AND OPTIONAL EQUIPMENT

STANDARD EQUIPMENT

Performances

- Axle oil cooling system
- Scania, Stage IV compliant, SCR, EGR, DOC, water-cooled, diesel engine with Variable Turbo Charger and air-to-air intercooler
- No DPF
- Engine power mode selector switch (Standard / Economy & Power mode)
- Power-up pedal function by full stroke of acceleration
- Auto shut-off engine
- Torque converter lock-up
- Transmission clutch cut-off via the brake pedal
- Transmission mode selector switch (Manual / Auto 1 ↔ 5 / Auto 2 ↔ 5 with kick-down)
- Hydraulic load sensing system, variable displacement pump
- Hydraulic lock differentials on front & rear axles
- Counterweight
- Robust Z bar lifting system

Maintenance

- Hydraulic reversing engine fan
- "DoosanCONNECT" Telematic system
- Self-diagnosis system & monitoring indicator by the dashboard, plus electronic plug for fast adjustment
- Fast couplers for hydraulic check
- External drains for engine oil and coolant changes

Comfort

- Load isolation system (LIS)
- Automatic lift arm kick-out
- Automatic return to dig
- Levelling function
- 3rd hydraulic function
- Automatic air conditioning with electronic climate control
- Grammer air-suspension seat with safety belt 2 points
- Mono control lever with FNR switch
- Adjustable steering column (tiltable & telescopic)
- Tinted safety glass
- Left sliding window
- Right opening window (180°)
- Floor mat
- Multiple storage compartments
- Cup holder
- Loudspeakers and connections for radio
- Shark antenna for radio
- Lift arm float kick-out
- Alternator 28 V / 100 Ah
- Dashboard monitoring with LCD display (dials, gauges and lamps)
- Interior cab light
- Cigarette lighter and 12 & 24 Volt power sockets

Safety

- Emergency steering pump driven by electric motor
- ROPS cab (SAE J 394, SAE 1040, ISO 3471)
- FOPS cab (SAE J 231, ISO 3449)
- Double filtered air cab
- Right opening window (emergency exit)
- Front and rear wiper and washer
- Retractable roller sun visor
- Road lights: low and high beam, tail indicators, stop, reversing lights
- Work lights: 2 halogen at the front and 4 at the rear (6 x 70 W)
- Reverse travel alarm
- Rotating beacon
- Horn
- Heated external mirrors
- Interior rear view mirrors
- Anti-slip steps & platforms
- Starting safety system
- Engine exhaust brake
- Brake circuits with accumulator
- Dual service brake pedals
- Electric parking brake on the transmission, spring-applied hydraulic release
- Wheel chocks

Other

- Bottom protection plates
- Tie hooks
- Articulation lock in the transport position
- Towing hitch
- Tyres 29.5 R25 (L3)

OPTIONAL EQUIPMENT

Performances

- Fuel heater
- High lift loader
- Quick coupler
- Wide range of buckets

Maintenance

- Bio oil
- Extended warranty

Comfort

- Fingertip levers
- Weighing system
- Electric joystick steering on armrest

Safety

- Work lights : 2 xenon at the front and 4 halogen at the rear (6 x 70 W)
- Full fenders with rubber protection

Other

- Tyres 29.5 R25 (L5)
- Automatic lubrication system



Some of these options may be standard in some markets. Some of these options may not be available for certain markets. Please check with your local DOOSAN dealer for more information about availability or to adapt your machine to your application needs.

PERFORMANCE GRAPH

1. EQUIPMENT STATUS

- Front option : Block handler lift arm and hydraulic system
- Attachment : Quick coupler with 1450mm fork
- Tire : L3 tires with Chain

■ Q/C+FORK PERFORMANCE GRAPH

DL550-5 BLOCK HANDLER (with reinforced Front, Q/C + Fork, L3 tire with Chain)

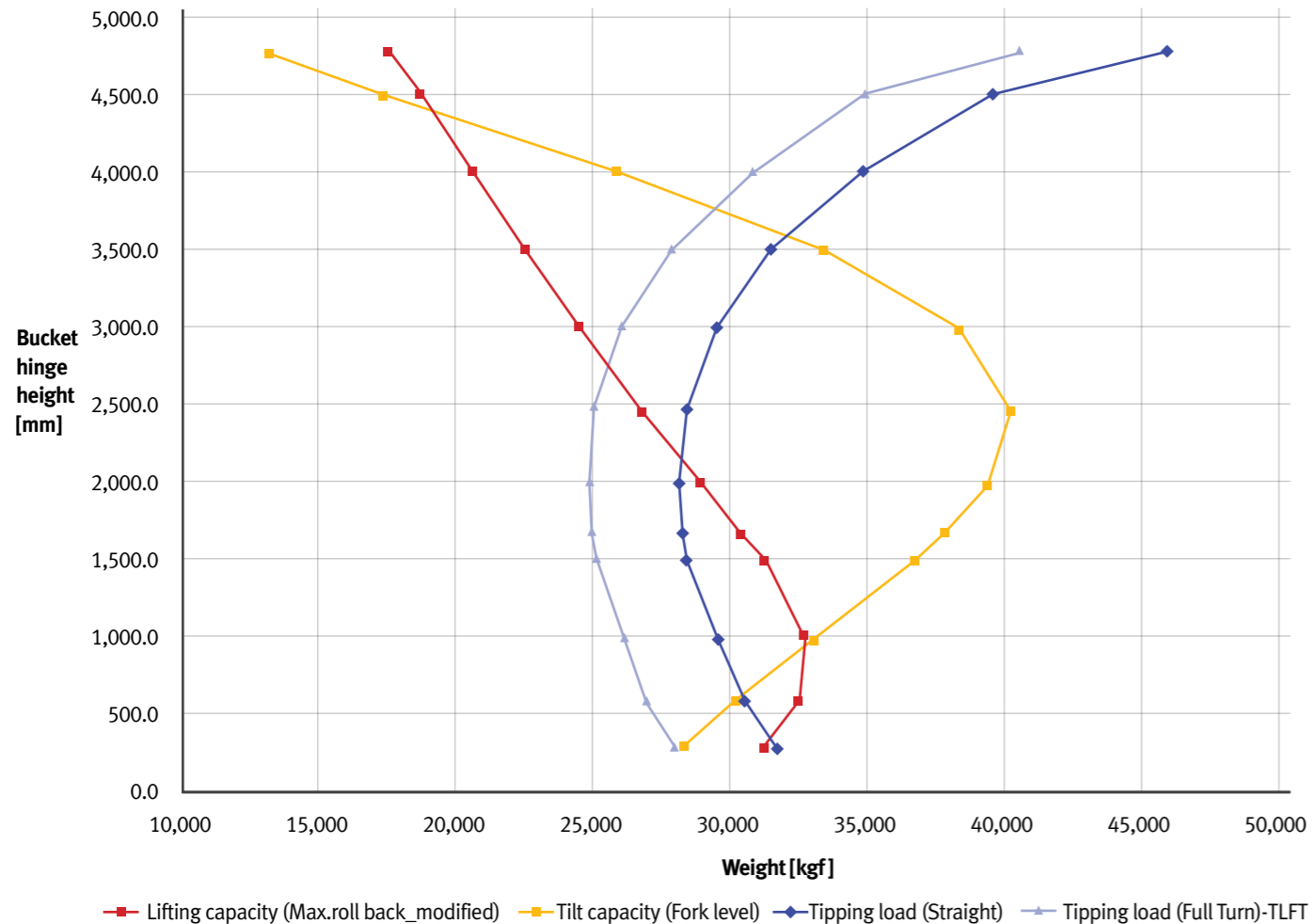

2. NOTE

- 2-1. Tipping load and rated operating load should be calculated according to ISO 14397-1.
- 50% of tipping load@full turn is normal operation for bucket or fork.
- 2-2. Heavy Single Object(HSO), such as marble, is according to ISO 14397-1 Annex A.
- Travel/transporting speed of less than 2 km/h
 - Firm and level ground
 - The load in a fully rolled back position
 - Machine must be in a straight-ahead position when loading the transport carrier.
 - Rated 80% of tipping load@full turn on firm and level ground or hydraulic limit takes the lesser result.
 - Load Center of gravity coordinates at X:900mm and Y:800 mm (below figure)

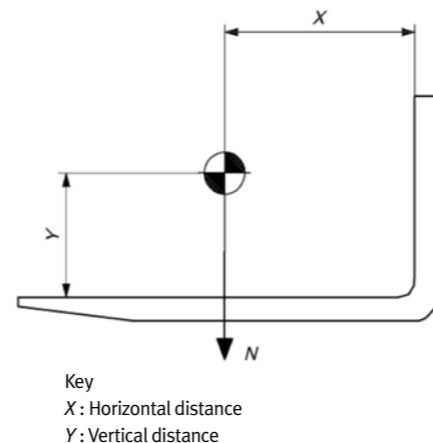

Doosan is

Since 1896, Doosan, the oldest company in Korea, has evolved with its people. The company grew up rapidly for last 10 years with reputation. For human-oriented vision, Doosan has been building constructions, energy, machines, infra structures globally. As a global leader of infra structure, Doosan continues its vision to make human-oriented future.

First in Korea, Doosan self-developed excavators in 1985 and continued building versatile construction machines including excavators, wheel loaders, articulated dump trucks to execute its human-oriented philosophy. Doosan became a global leader of heavy construction machine industry by achieving global sales line, producing line, and distribution line. Along with large production bases in Korea, China, USA, Belgium, Czech, Brazil, Doosan has 1400 dealer networks and Doosan is providing reliable products and trusted solutions for your stable business at no risk.



Doosan Infracore Korea Office (HQ)
 27F, Doosan Tower, 275, Jangchungdan-ro,
 Jung-gu, Seoul, Korea(04563)
 Tel : 82 2 3398 8114

www.doosaninfracore.com/ce/