

DOOSAN

Construction Equipment

DX260LCA

Engine Power	Gross Power	143kW (195PS, 192HP) @ 1,800rpm (SAE J1995)
	Net Power	136kW (185PS, 183HP) @ 1,800rpm (SAE J1349)
Operational Weight	24,800 ~ 25,100 kg	
Bucket Capacity (SAE/PCSA)	0.51 ~ 1.51 m ³	





**DOOSAN DX260LCA HYDRAULIC EXCAVATOR :
EXCELLENT PRODUCTIVITY,
QUALITY & DURABILITY**

DX260LCA

DX260LCA has been built for the industry's best productivity and cycle times. Through large size engine and pump, DX260LCA has the best productivity among equivalent models.



7 INCH MONITOR

- New, user-friendly LCD color monitor with full access to machine settings and maintenance data.
- Operator can see rear view through new monitor (If customer selects rear view camera option)



TROPICAL HYDRAULIC OIL (ISO VG 68)

- Maintain best performance of your machine by keeping optimum viscosity in tropical area.



HEAVY-DUTY FRONT

- Overall reinforcement of steel plate by increasing thickness. (Side plate 20%, Bottom 15%)
- Reinforced boom-end bracket and enlarged arm-center boss
- Enlarged arm-end boss and reinforcement plate with abrasion-resistant beams.



ADVANCED HD CABIN (OPTIONAL)

- ROPS, FOPS optional
- The latest interior (MP3, Joystick, Air suspension seat, etc.)



ADVANCED FRONT BUSH

- EM bushing (Enhanced Macro-surface)
- Pocket & Dimple surface pattern : Optimized greasing & Trap foreign object
- Wear resistant solid lubricant coating : Noise free & enhanced anti-seizure property
- 30% longer life time than competitors



PRE CLEANER

- Install rotor type pre-cleaner (Donaldson Top Spin 5"). So filtering efficiency 20% increased



WATER SEPARATOR

- Fuel water separator filters water in fuel and enhance engine's durability and reduce quality problem caused by water in fuel (Extra Filter + Pre Filter + Main Filter)



ADVANCED H-CLASS BUCKET

- Doosan new H-class bucket has the best strength of steel & the optimized design
- Add side cutter / add chamfer and inner plate at member part
- Increase bucket solidity and change casting type



ADVANCED UNDERCARRIAGE

- Strengthen Sprocket structure and tooth
- Structure to prevent debris



PERFORMANCE & PRODUCTIVITY

DX260LCA

The performance of the DX260LCA has a direct effect on its productivity. Its new improved engine and new EPOS™ controlled hydraulic system have combined to create an unbeatable hydraulic excavator, with a cost/performance ratio that makes the DX260LCA even more appealing.



DOOSAN ENGINE(DE08TIS)

Doosan product gives high performance through in-house engine

Doosan engine(In-house) perfectly harmonized with the hydraulic system and provides strong power. Mechanical engine provides high resistance to moisture, dust, and bad fuel quality. The best engine power in the industry(192HP) provides stable working speed even in the heavy workload situation.

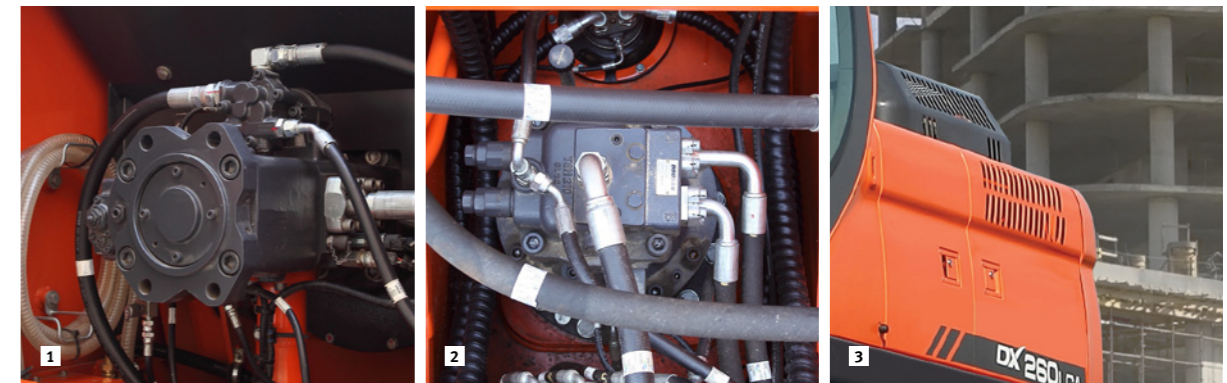

1 HYDRAULIC PUMP

The Main pump has a capacity of 2 x 230 l/min reducing cycle time while a high capacity gear pump improves pilot line efficiency.

2 SWING DRIVE

Shocks during rotation are minimized, while increased torque is available to ensure rapid cycles.

3 TRAVEL DEVICE

In house travel device provides simple internal structure and increases efficiency of the performance. Thicker sprocket minimizes incoming debris and provides higher durability.

EXCAVATOR CONTROL

Improved Excavator control by New EPOS™ system
The brains of the hydraulic excavator, the EPOST™ (Electronic Power Optimizing system), have been improved, through a CAN (Controller Area Network) communication link, these units are now perfectly synchronised.

SMOOTH AND FAST SWING BY INCREASED SWING TORQUE

- 4~6% more productive than the previous model
- DX260LCA will complete various challenging jobs, (especially when required instant power) with better productivity than the previous model

* Above image may differ from actual product.



DURABILITY & RELIABILITY

DX260LCA

The reliability of an item of plant contributes to its overall lifetime operating costs. DOOSAN uses computer-assisted design techniques, highly durable materials and structures then test these under extreme conditions.



HEAVY DUTY BOOM & ARM BOOM (STANDARD)

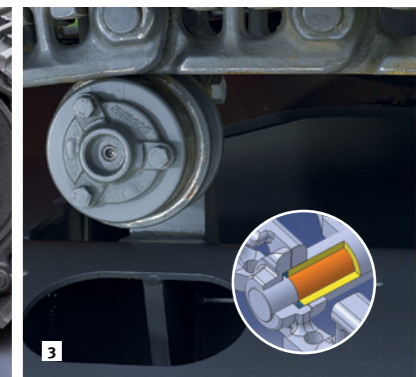
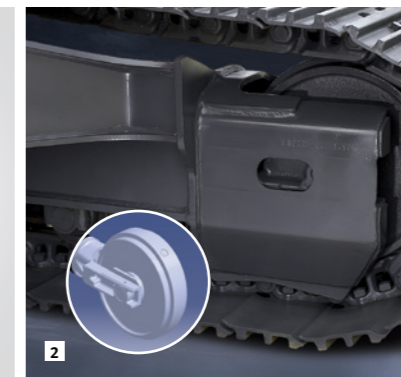
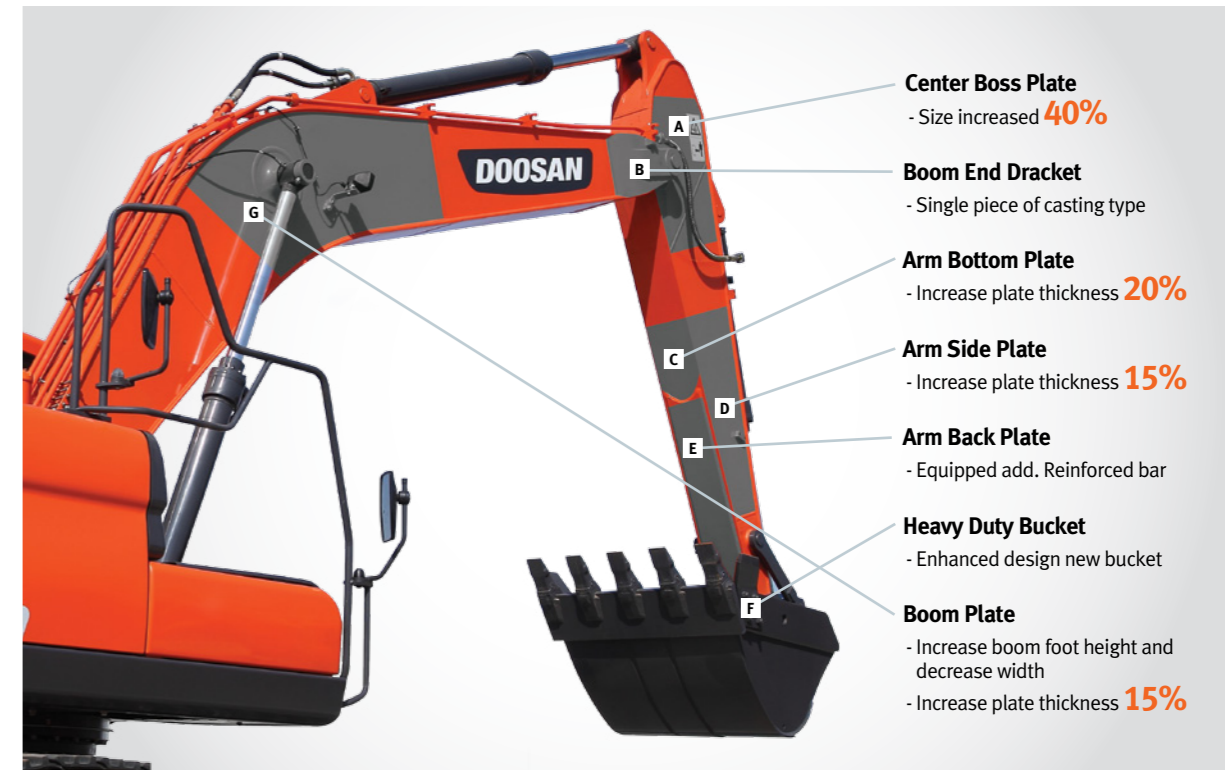

1 ADVANCED PIN-BUSH AND DISK / SHIM TECHNOLOGY

Pocket & Dimple surface pattern : Optimized greasing & Trap foreign object

- Wear resistant solid lubricant coating :
Noise free & enhanced anti-seizure property.
- Polymer shim with hard metal disk (90% less abrasion)
- Hard metal anti-wear disk (75% less abrasion)

2 INTEGRATED TRACK SPRING AND IDLER

The track spring and the idler have been joined directly to achieve high durability and improved maintenance convenience.

3 TRACKS

The chain is composed of self-lubricating sealed links isolated from all external contamination. The tracks are locked by mechanically bolted pins.

* Above image may differ from actual product.



MARKET NO.1 FUEL EFFICIENCY IN MIDDLE EXCAVATOR.

"NEW CONTROL LOGIC" for Better Fuel Efficiency

① Fuel Efficiency **8.8%** BETTER ↑
 ② Fuel consumption **7.0%** SAVING ↓

* Above image may differ from actual product.

RELIEF CUTOFF

The pump continues to supply flow even when the maximum pressure on the system is reached due to severe working environments and large workloads. Relief cutoff technology of DX225LCA prevents transfer of unnecessary flow to maintain powerful working level at the maximum value while reducing consumption of fuel.



OPTIMIZED LEVER CONTROL & AUTO IDLE

When operator takes a break and leaves the control joystick fixed, both of the engine and the pump are kept in standby mode and prevents unnecessary fuel consumption.



PUMP MATCHING TECHNOLOGY

Engine & pump matching, the new technology of Doosan, fully resolves problems; low responses time of the system, unnecessary fuel consumption. Matching response time between pump and engine efficiently reduces unnecessary fuel consumption as well as exhaust fumes.

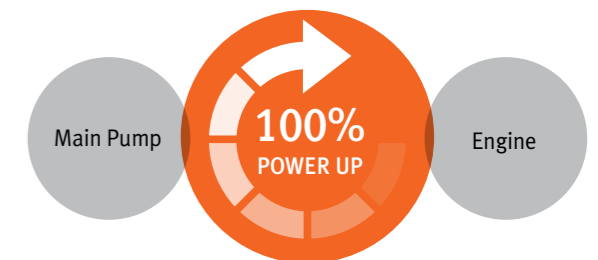
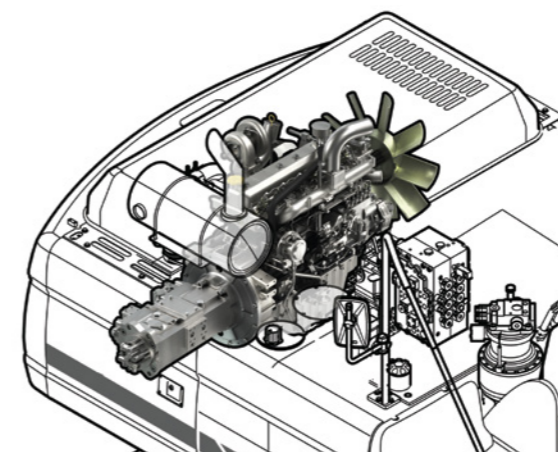



OPERATOR COMFORT

DX260LCA

More space, better visibility, air conditioning, a very comfortable seat. These are all elements that ensure that the operator can work for hours and hours in excellent conditions.



MONITOR



3 power modes for maximum efficiency
- Power mode
- Standard mode
- Economy mode

3 work modes to suit your application
- 1-way mode
- 2-way mode
- Digging mode

- 1 Control panel
- 2 Navigation modes
- Rearview camera, Display selector
- 3 Working modes
- Auto-idle & Flow rate control



1 CONTROL LEVER

Very precise control of the equipment increases versatility, safety and facilitates tricky operations requiring great precision. Levelling operations and the movement of lifted loads in particular are made easier and safer. DOOSAN designed the DX260LCA by putting the operator at the center of the development goals. The result is significant ergonomic value that improves the efficiency and safety of the operator. More space, better visibility, air conditioning, a very comfortable seat... These are all elements that ensure that the operator can work for hours and hours in excellent conditions.

2 SLIDING SEAT

4 REAR VIEW CAMERA (OPTIONAL)

AIR CONDITIONING WITH CLIMATE CONTROL

The high performance air conditioning provides an air flow which is adjusted and electronically controlled for the conditions. Five operating modes enable even the most demanding operator to be satisfied.



2 AIR SUSPENSION SEAT (OPTIONAL)

Equipped with various functions of adjustment forth and back and, and lumbar support, it reduces the vibration of equipment transmitted during work in an effective way. Also for considering winter working environment, Seat warmer functions equipped.



CONTROL PANEL The control panel is clear, simple to read and positioned for easy use, allowing you to work safely and confidently.

* Above image may differ from actual product.



EASY MAINTENANCE

DX260LCA

Short maintenance operations at long intervals increase the availability of the equipment on site. DOOSAN has developed the DX260LCA with a view to high profitability for the user.



* Option spec info is included to the images contained in this material and may not be the same with the actual specs.



1 REMOTE GREASING POINTS

To make maintenance easier, the arm and boom greasing points have been centralized. Remote a grouped greasing points on boom & arm.

2 FUEL FILTER

High efficiency fuel filtration is attained by the use of multiple filters, including a fuel prefilter fitted with a water separator that removes most moisture from the fuel.

3 CONVENIENT FUSE BOX

The fuse box is conveniently located in a section of the storage compartment behind the operator's seat providing a clean environment and easy access.

4 WATER SEPARATOR

High efficiency and large capacity water separator protect the engine by removing most moisture from the fuel.

5 PRE CLEANER

Install rotor type pre-cleaner (Donaldson Top Spin 5"). So filtering efficiency 20% increased

6 NEW BATTERY BOX

- a. Larger anti-slip surface
- b. New spring to facilitate fixing
- c. Cut-off switch easier to reach
- d. New locking device

7 PC MONITORING (DMS)

A PC monitoring function enables connection to the EPOS™ system, allowing various parameters to be checked during maintenance, such as pump pressures, engine rotation speed, etc. and these can be stored and printed for subsequent analysis.

8 CENTRALIZED GREASE INLETS FOR EASY MAINTENANCE

The boom & arm grease inlets are grouped for easy access.

9 NEW HANDRAIL & GUARDRAIL

The new fittings are now ISO 2867:2007 compliant. Access is facilitated and the writings have been strongly reinforced.



HYDRAULIC OIL RETURN FILTER

The protection of the hydraulic system is made more effective by the use of glass fiber filter technology in the main oil return filter. This means that with more than 99.5% of foreign particles filtered out, the oil change interval is increased.

AIR CLEANER

The large capacity forced air cleaner removes over 99% of airborne particles, reducing the risk of engine contamination and making the cleaning and cartridge change intervals greater.



* Above image may differ from actual product.

TELEMATICS SERVICE (OPTIONAL)

GLOBAL PARTS NETWORK

TELECOMMUNICATIONS

Data flow from machine to web



TELEMATICS SERVICE TERMINAL

Telematics Service terminal is installed to machine / connected to EPOS™



TELECOMMUNICATION

GPS, EPOS™ data is sent to designated server by GSM, Satellite telecommunication



DOOSAN TELEMATICS SERVICE WEB

Doosan, Dealer, Customer can easily monitor the GPS, EPOS™ data from Core Telematics Service web

BENEFITS

JOB SITE MANAGEMENT



WORK EFFICIENCY MANAGEMENT



PREVENTIVE MAINTENANCE

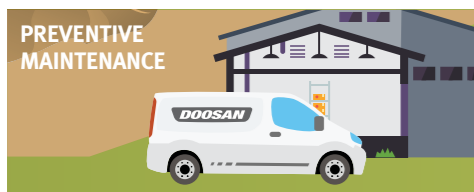

PROACTIVE SERVICE



FUNCTIONS

Location

- GPS
- Geo-fence

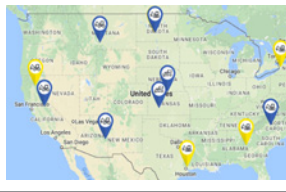

Operation Trend

- Total operation hour
- Operation hour by mode



Filter & Oil Management

- Preventive maintenance by item replacement cycle



Warning & Alert

- Detect machine warnings
- Antenna disconnection
- Geo/Time fence

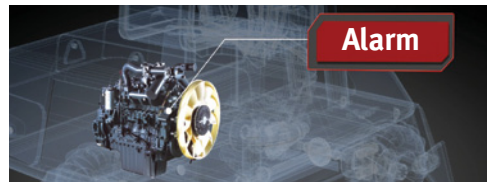

Reports

- Periodic operation report
- Utilization



Fuel Efficiency*

- Fuel level
- Fuel consumption



* Functions may not be applied to all models. Please contact your sales representative to get more information of the service.

TELEMATICS SERVICE BENEFITS

Customer

- Improve work efficiency
- Timely and preventive service
- Improve operator's skills by comparing work pattern
- Manage fleet more effectively

Dealer

- Better service for customers
- Provide better quality of service
- Maintain machine value
- Better understanding of market needs

Doosan

- Responsive to customer's voice
- Utilize quality-related field data
- Apply customer's usage profile to developing new machine

GLOBAL PDC (PARTS DISTRIBUTION CENTER) NETWORK

Doosan provides fast and precise worldwide delivery of genuine Doosan parts through its global PDC (parts distribution center) network.

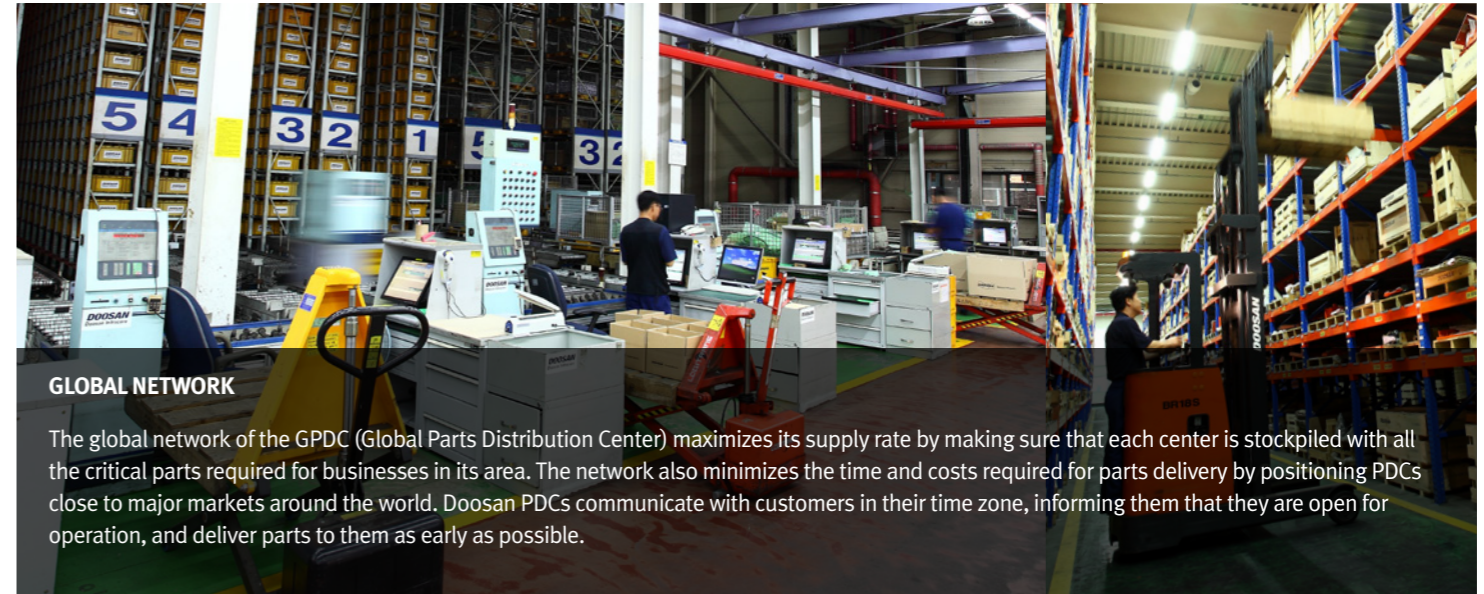

The Global Parts Distribution Center Network

PDCs had been set up as shown below, including Mother PDC in Ansan, Korea. The eight other PDCs include one in China (Yantai), two in the USA (Chicago and Miami), one in Brazil (Campinas), two in Europe (Germany and the UK), one in the Middle East (Dubai), and one in Asia (Singapore).



PDC BENEFIT

- Distribution Cost Reduction
- Maximum Parts supply rate
- Shortest distance/time parts delivery
- Real-time service support
- Minimum downtime

Heavy Construction Bucket, which is also called Heavy Duty bucket, is the most commonly used bucket in the construction equipment market and is designed mainly for use in heavy construction but also used in low density mining and quarry application.

Hinge
Optimized reinforced construction for high strength and performance matched to the machine's power.

Adapter
Corner adapter Positioned under Side cutter to increase strength.

Wrapper (Shell)
Shape increases heel clearance and decreases wear rate.

Horizontal Bottom Wear Plates
Protects bottom section and reinforces bucket for greater strength and rigidity. Designed for easily replacement during maintenance repair.

Lip Plate (Cutting Edge)
Beveled edge for better penetration and 500BHN material for high abrasion resistance.

Tooth (Tip)
Designed with mechanical properties that maintain hardness for long wear life in tough digging applications.

Side cutter
Designed for better penetration and used high wear resistant material.

Side Wear Plates
Side plates meet up with bottom wear plates for seamless corner protection.



General Purpose bucket

which is also called General Purpose bucket, is designed for digging and re-handling soft to medium materials e.g. materials with low wear characteristics such as top-soil, loam, coal.



Heavy Duty bucket

which is also called Heavy Duty bucket, is the most commonly used bucket in the construction equipment market and is designed mainly for use in heavy construction but also used in low density mining and quarry application.



Severe Duty bucket

which is also called Severe Duty bucket. The bucket is designed for use in high density mining and quarry application using high strength and high abrasion resistance materials. It can be used in the toughest of applications.

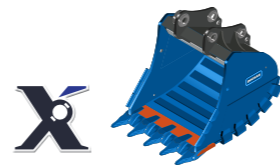

Extra Severe Duty Bucket

which is also called X class bucket. The bucket is designed for use in high density mining and quarry application using high strength and high abrasion resistance materials. It can be used in the toughest of applications.

TOOTH

GD (General Duty) Tooth
Optimized design for Doosan's GP and the new General Construction bucket. Suitable for machines ranging from 14 to 70 tons. Recommended for general construction and utility loading applications.

HD (Heavy Duty) Tooth
Optimized design for the Heavy Construction bucket. Suitable for machines ranging from 14 to 70 tons. Recommended for most applications including excavating, trenching, loading and medium density quarries and mining.

SD (Severe Duty) Tooth
Optimized design for the Severe Mining bucket and the Xtreme Mining bucket. Suitable for machines ranging 22 to 70 tons. Recommended for extremely tough quarries and mining application.

BUCKET



	Capacity (Width) [m ³ (mm)]
GENERAL PURPOSE BUCKET	0.51(768) / 0.81(1,125) / 0.92(1,233) / 1.05(1,369) / 1.10(1,367) / 1.17(1,490) / 1.28(1,604) / 1.40(1,658)
HEAVY DUTY BUCKET	0.60(796) / 0.76(946) / 0.92(1,096) / 1.08(1,246) / 1.24(1,396) / 1.35(1,496) / 1.40(1,546) / 1.51(1,646)
SEVERE DUTY BUCKET	0.91(1,094) / 1.07(1,244) / 1.23(1,394)

DEMOLITION



	Model	Weight	Tool diameter	Frequency
HYDRAULIC BREAKER	DXB180H	1,720 kg	140 mm	320~580 BPM
	Model	Weight	Max. Jaw opening	Force at Tip
FIXED PULVERIZER	FP25	1,890 kg	889 mm	64 t
ROTATING CRUSHER	RC25	2,300 kg	925 mm	67 t
MULTI-PROCESSOR	C / D / P / S MP22	2,040 / 2,050 / 2,210 / 1,880 kg	903 / 797 / 893 / 503 mm	68 / 70 / 64 / 80 t

C : Crushing jaw
D : Demolition jaw
P : Pulverizing jaw
S : Shearing jaw

MATERIAL HANDLING



	Model	Weight	Max Jaw opening	Max. Closing Force	Capacity
MULTI-GRAPPLE	MG22	1,423 kg	2,044 mm	5.7 t	0.75 m ³
STONE GRAPPLE	SG25	1,335 kg	2,000 mm	-	0.45 m ²
WOOD GRAPPLE	L / P WG25	1,232 / 1,110 kg	2,000 mm	-	0.62 m ²
LOG GRAPPLE	L / P LG25	1,380 / 1,350 kg	2,000 mm	-	0.67 m ²
ORANGE GRAPPLE	OG22	1,300 kg	2,150 mm	-	0.5 m ³

L : Link type
P : Pendulum type

EARTH MOVING



	Model	Weight	Max. Jaw opening	Capacity
CLAMSHELL BUCKET	CB25	1,560 kg	1,725 mm	1.00 m ³
	Model	Weight	Base plate (WxL)	Impulse force
PLATE COMPACTOR	PC22	1,325 kg	860 x 1,200 mm	11.2 t
	Model	Weight	Length	
RIPPER	RP22	450 kg	1,278 mm	

CONNECTING



	Model	Weight	Bucket Pin dia.	Working rage (Pin to Pin)
QUICK COUPLER	QC22	319 kg	80 mm	445 ~ 514 mm

TECHNICAL SPECIFICATIONS

ENGINE

Model
Doosan DE08TIS Mechanical engine with direct fuel injection 2 valves per cylinder, vertical injectors, water cooled, turbo charged with air to air intercooler. The emission levels are well below the values required for phase II
Number of cylinders
6
Nominal flywheel power
Gross Power 143kW (195PS, 192HP) @ 1,800rpm (SAE J1995) Net Power 136kW (185PS, 183HP) @ 1,800rpm (SAE J1349)
Max torque
85 kgf.m at 1,400 rpm
Piston displacement
8,071 cc
Bore & stroke
Ø111 x 139 mm
Starter
24 V x 6.0 kW
Batteries
24 V / 150 AH
Air cleaner
Double element with auto dust evacuation.

SWING MECHANISM

- An axial piston motor with two-stage planetary reduction gear is used for the swing.
- Increased swing torque reduces swing time.
- Internal induction-hardened gear.
- Internal gear and pinion immersed in lubricant bath.
- The swing brake for parking is activated by spring and released hydraulically.

TYPE : AXIAL PISTON
MAX SWING TORQUE : 9,860 kgf.m
Swing speed : 10.4 rpm

WEIGHT

Shoe width	Ground pressure (kgf/cm ²)	Machine Weight (ton)
(Std) 600 mm	0.51 kgf/cm ²	24.8/*25.0
(Opt) 700 mm	0.44 kgf/cm ²	25.2/*25.4
(Opt) 800 mm	0.39 kgf/cm ²	25.5/*25.7
(Opt) 900 mm	0.35 kgf/cm ²	25.8/*26.0

HYDRAULIC SYSTEM

The heart of the system is the EPOS (Electronic Power Optimizing System). It allows the efficiency of the system to be optimized for all working conditions and minimizes fuel consumption. The new EPOS is connected to the engine electronic control via a data transfer link to harmonize the operation of the engine and hydraulics.

- The hydraulic system enables independent or combined operations.
- Cross-sensing pump system for fuel savings.
- Auto deceleration system.
- Button control of flow in auxiliary equipment circuits.
- Computer-aided pump power control.

Main pumps
Swash Plate, Axial Piston Max flow: 2-230 Liter/min Displacement: 127.8 cc/rev Quantity: 2EA
Pilot pump
Gear Pump - Max Flow Rate-27 l/min Displacement:15 cc/rev Relief valve Pressure - 40 kgf/cm ²
Maximum system pressure
Boom/arm/Bucket : - Normal mode: 330 kgf/cm ² Working,Travel - 330 kg/cm ² Pressure Up - 350 kgf/cm ²

DRIVE

Each track is driven by an independent axial piston motor through a planetary reduction gearbox. Two levers with control pedals guarantee smooth travel with counter-rotation on demand.

Travel speed (fast/slow)
3.4 / 5.8 km/hr
Maximum traction force
26.8 / 15.6 ton
Maximum grade
70%

UNDERCARRIAGE

Chassis are of very robust construction, all welded structures are designed to limit stresses. High-quality material used for durability. Lateral chassis welded and rigidly attached to the undercarriage. Track rollers lubricated for life, idlers and sprockets fitted with floating seals. Tracks shoes made of induction-hardened alloy with double grouser. Heat-treated connecting pins. Hydraulic track adjuster with shock-absorbing tension mechanism.

Number of rollers and track shoes per side
Upper rollers: 2 (standard shoes) Lower rollers: 10 Shoes: 51 Total length of track: 4,625mm (15'2")

HYDRAURIC CYLINDERS

Cylinders	Quantity	Bore x Rod x Stroke
Boom	2	130 x 90 x 1,355
Arm	1	140 x 100 x 1,705
Bucket	1	130 x 90 x 1,080

DIGGING FORCES (ISO)

DX260LCA	Unit	Boom : 5,900mm Arm : 3,000mm Bucket : 1.17 m ³	Boom : 5,900mm Arm : 2,500mm Bucket : 1.40 m ³	Boom : 5,900mm Arm : 3,500mm Bucket : 1.17 m ³	Boom : 5,900mm Arm : 3,000mm Bucket : 1.24 m ³ H class
Bucket (Normal/Press up)	t	16.8 / 17.8	17.3 / 18.4	16.8 / 17.8	16.4 / 17.4
	kN	165 / 174	170 / 180	165 / 174	161 / 171
Arm (Normal/Press up)	t	11.7 / 12.4	13.8 / 14.6	10.5 / 11.1	11.7 / 12.4
	kN	115 / 122	135 / 143	103 / 109	115 / 122

BUCKET

Bucket Type	Capacity		Width		Weight	TRACK	STD Track	Narrow	
	SAE/PCSA	CECE	W/O Cutter	With Cutter		C/W (ton)	4.7	4.7	
						SHOE (mm)	600	600	
GP	0.51 m ³	0.47 m ³	722 mm	722 mm	534 kg	A	A	A	
	0.81 m ³	0.72 m ³	1064 mm	1126 mm	667 kg	A	A	A	
	0.92 m ³	0.81 m ³	1172 mm	1236 mm	707 kg	A	A	A	
	1.05 m ³	0.92 m ³	1308 mm	1370 mm	759 kg	A	A	A	
	1.10 m ³	0.95 m ³	1316 mm	1377 mm	846 kg	A	A	A	
	1.17 m ³	1.0 m ³	1428 mm	1491 mm	817 kg	A	A	A	
	1.28 m ³	1.11 m ³	1544 mm	1607 mm	856 kg	A	A	B	
	1.40 m ³	1.22 m ³	1607 mm	1668 mm	985 kg	A	B	C	
H Class	0.60 m ³	0.56 m ³	750 mm	796 mm	706 kg	A	A	A	
	0.76 m ³	0.69 m ³	900 mm	946 mm	778 kg	A	A	A	
	0.92 m ³	0.83 m ³	1,050 mm	1,096 mm	867 kg	A	A	A	
	1.08 m ³	0.97 m ³	1,200 mm	1,246 mm	939 kg	A	A	B	
	1.24 m ³	1.11 m ³	1,350 mm	1,396 mm	1,011 kg	A	B	C	
	1.35 m ³	1.20 m ³	1,450 mm	1,496 mm	1,077 kg	B	C	C	
	1.40 m ³	1.24 m ³	1,500 mm	1,546 mm	1,101 kg	B	C	D	
	1.51 m ³	1.34 m ³	1,600 mm	1,646 mm	1,166 kg	C	D	D	
S Class	0.91 m ³	0.82 m ³	1,050 mm	1,094 mm	1,078 kg	A	A	A	
	1.07 m ³	0.96 m ³	1,200 mm	1,244 mm	1,182 kg	A	B	B	
	1.23 m ³	1.10 m ³	1,350 mm	1,394 mm	1,262 kg	B	C	C	
Maximum load pin-on (payload+bucket)						4,169	3,805	3,472	3,561

Based on ISO 10567 and SAE J296, arm length without quick change clamp
A : Suitable for materials with density of 2,100kg/m³ (3,500lb/yd³) or less
B : Suitable for materials with density of 1,800kg/m³ (3,000lb/yd³) or less
C : Suitable for materials with density of 1,500kg/m³ (2,500lb/yd³) or less
D : Suitable for materials with density of 1,200kg/m³ (2,000lb/yd³) or less
X : Not recommended

REFILL CAPACITIES

Fuel tank
420L(diesel)
Cooling system (Radiator capacity)
25L(water)
Engine oil
34L
swing device
5L
travel device
2 x 4L
oil tank
240L

This bucket recommendation is based on machine stability considering the tipping load with certain density of handling material, and should be strictly followed. It's more recommendable to use a smaller size of bucket than recommendation under the severe working condition and application to avoid the durability risks.

* : for ROPS

DIMENSIONS

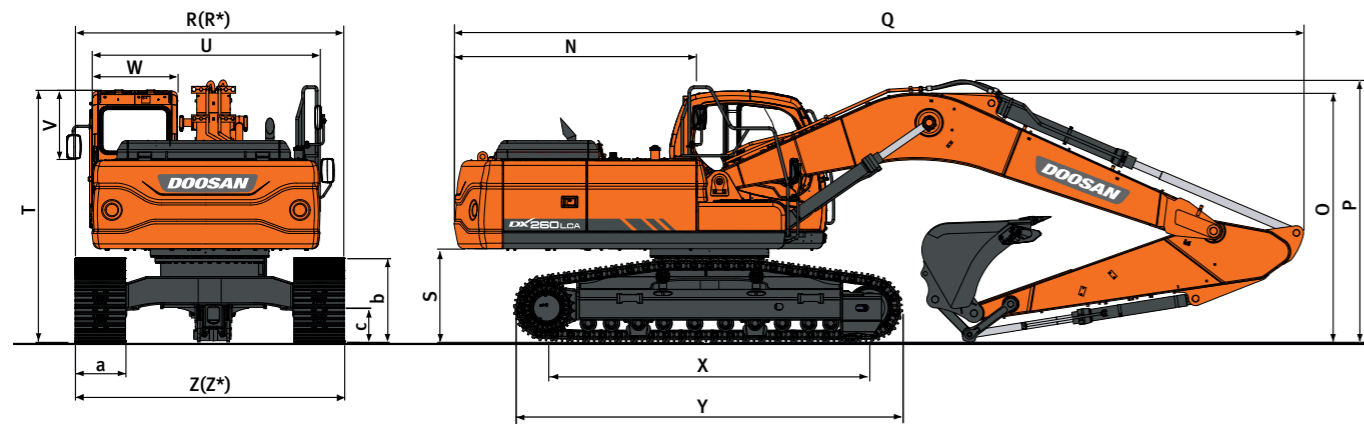

DIMENSIONS

Boom type (One piece)	(mm)		5,900					
Arm type	(mm)		3,000		2,500		3,500	
Bucket type (SAE)	(mm ³)		1.1	1.17	1.28	1.17	1.14	1.17
Tail Swing Radius	(mm)	N	3,035	←	←	←	←	←
Shipping Height (Boom)	(mm)	O	2,995	2,995	2,995	3,080	3,080	3,380
Shipping Height (Hose)	(mm)	P	3,195	3,195	3,195	3,300	3,300	3,555
Shipping Length	(mm)	Q	10,075	10,075	10,075	10,140	10,140	10,100
Shipping Width (Std.)	(mm)	R	3,200	←	←	←	←	←
Shipping Width (Narrow)	(mm)	R*	3,000	←	←	←	←	←
C/Weight Clearance	(mm)	S	1,110	←	←	←	←	←
Height Over CAB.	(mm)	T	2,970	←	←	←	←	←
House Width	(mm)	U	2,710	←	←	←	←	←
CAB. Height Above House	(mm)	V	835	←	←	←	←	←
CAB. Width	(mm)	W	1,010	←	←	←	←	←
Tumbler Distance	(mm)	X	3,835	←	←	←	←	←
Track Length	(mm)	Y	4,625	←	←	←	←	←
Undercarriage Width (Std.)	(mm)	Z	3,200	←	←	←	←	←
Undercarriage Width	(mm)	Z*	3,000	←	←	←	←	←
Shoe Width	(mm)	a	600	←	←	←	←	←
Track Height	(mm)	b	995	←	←	←	←	←
Car Body Clearance	(mm)	c	450	←	←	←	←	←

WORKING RANGES

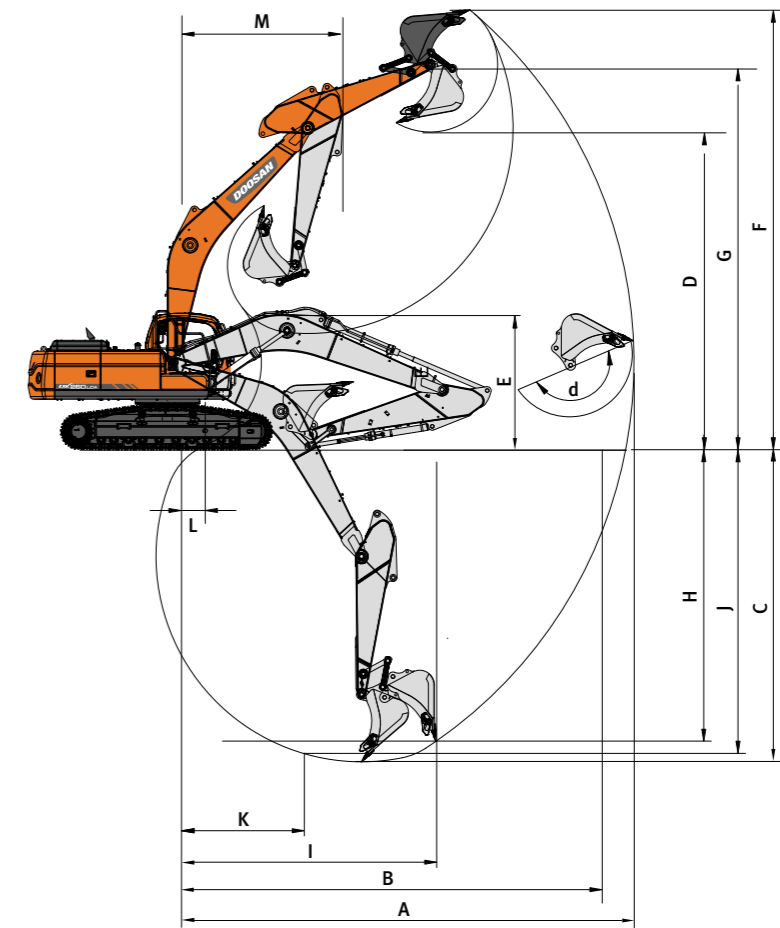

WORKING RANGES

Boom type (One piece)	(mm)		5,900					
Arm type	(mm)		3,000		2,500		3,500	
Bucket type (SAE)	(mm ³)		1.1	1.17	1.28	1.17	1.14	1.17
Max. Digging Reach	(mm)	A	10,180	10,165	10,165	9,680	9,695	10,635
Max. Digging Reach (Ground)	(mm)	B	10,010	9,980	9,980	9,485	9,500	10,460
Max. Digging Depth	(mm)	C	6,800	6,780	6,780	6,285	6,290	7,285
Max. Loading Height	(mm)	D	6,940	6,955	6,955	6,675	6,660	7,190
Min. Loading Height	(mm)	E	2,560	2,570	2,570	3,060	3,045	2,070
Max. Digging Height	(mm)	F	9,600	9,670	9,670	9,365	9,295	9,905
Max. Bucket Pin Height	(mm)	G	8,410	8,410	8,410	8,130	8,130	8,645
Max. Vertical Wall Depth	(mm)	H	5,205	5,925	5,925	5,290	4,575	6,410
Max. Radius Vertical	(mm)	I	7,225	5,365	5,365	6,390	7,160	6,500
Max. Depth to 8' Line	(mm)	J	6,615	6,595	6,595	6,060	6,075	7,120
Min Radius 8' Line	(mm)	K	2,995	2,980	2,980	2,955	2,930	3,015
Min. Digging Reach	(mm)	L	630	655	655	1,731	1,707	0
Min. Swing Radius	(mm)	M	3,845	3,845	3,845	3,885	3,885	3,870
Bucket Angle	(deg)	d	174	186	186	186	175	186

LIFTING CAPACITY

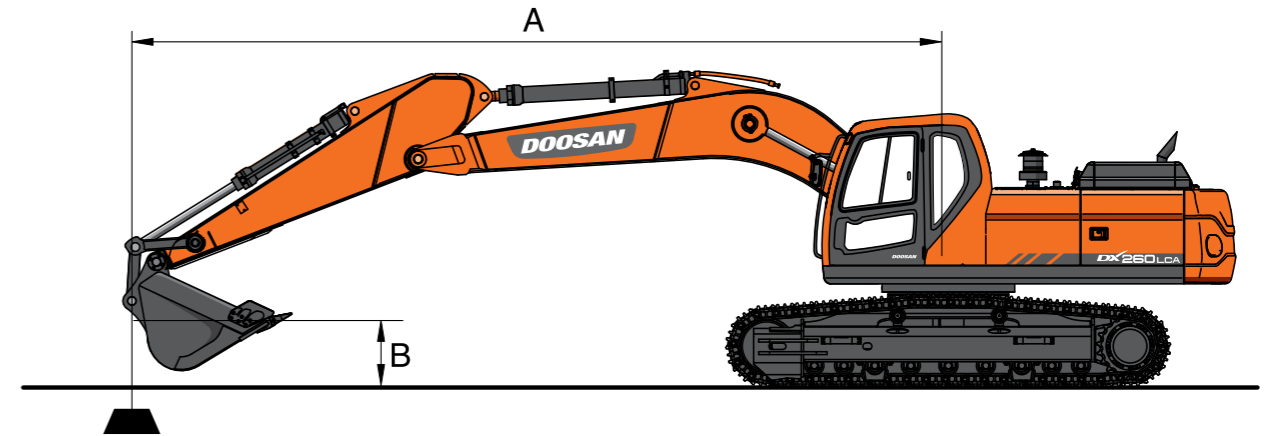
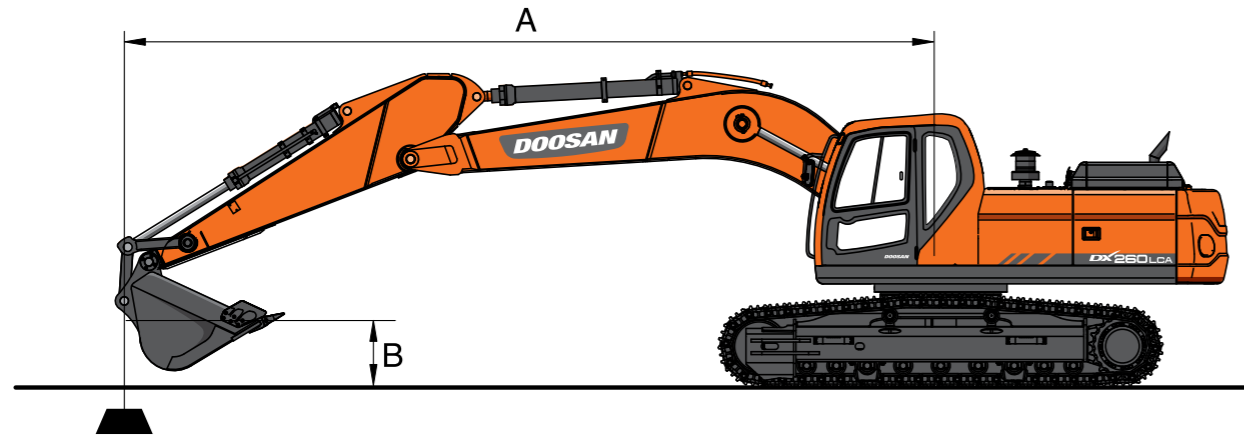

Standard

Metric

Boom : 5.9m One-Piece Boom Arm : 2.5m Bucket : Without Bucket Shoe : 600mm

Unit : 1,000kg

A(m)	3		4.5		6		7.5		Max. Reach		A(m)
7.5									*6.61	*6.61	5.99
6					*6.65	*6.65			*6.23	5.14	7.12
4.5			*8.80	*8.80	*7.30	6.59	*6.64	4.67	*6.20	4.38	7.80
3			*10.96	9.55	*8.26	6.29	6.71	4.55	5.9	4.01	8.15
1.5			*12.59	9.02	*9.13	6.03	6.57	4.42	5.75	3.88	8.21
0			*13.09	8.81	*8.98	5.86	6.48	4.33	5.92	3.98	7.99
-1.5	*12.13	*12.13	*12.69	8.8	8.93	5.82			6.52	4.36	7.47
-3	*15.25	*15.25	*11.37	8.93	*8.51	5.91			*7.47	5.27	6.56
-4.5	*11.23	*11.23	*8.39	*8.39					*7.16	*7.16	5.08

Option 1

Metric

Boom : 5.9m One-Piece Boom Arm : 2.5m Bucket : Without Bucket Shoe : 800mm

Unit : 1,000kg

A(m)	3		4.5		6		7.5		Max. Reach		A(m)
7.5									*6.61	*6.61	5.99
6					*6.65	*6.65			*6.23	5.27	7.12
4.5			*8.80	*8.80	*7.30	6.75	*6.64	4.79	*6.20	4.49	7.80
3			*10.96	9.79	*8.26	6.45	6.89	4.67	6.06	4.11	8.15
1.5			*12.59	9.26	*9.13	6.19	6.75	4.54	5.91	3.99	8.21
0			*13.09	9.05	9.23	6.02	6.66	4.45	6.09	4.09	7.99
-1.5	*12.13	*12.13	*12.69	9.04	9.18	5.98			6.7	4.48	7.47
-3	*15.25	*15.25	*11.37	9.17	*8.51	6.07			*7.47	5.41	6.56
-4.5	*11.23	*11.23	*8.39	*8.39					*7.16	*7.16	5.08

1. Ratings are based on SAE J1097
2. Load point is the end of arm.
3. * Rated loads are based on hydraulic capacity.
4. Rated loads do not exceed 87% of hydraulic capacity or 75% of tipping capacity.

: Rating Over Front
 : Rating Over Side or 360 degree

Option 2

Metric

Boom : 5.9m One-Piece Boom Arm : 3.0m Bucket : Without Bucket Shoe : 600mm

Unit : 1,000kg

A(m)	1.5		3		4.5		6		7.5		Max. Reach		A(m)		
7.5											*4.77	*4.77	6.64	*3.90	7.25
6							*6.07	*6.07	*5.31	4.77	*4.51	*4.51	7.67	*3.71	8.21
4.5							*6.78	6.65	*6.20	4.69	*4.47	3.96	8.31	3.6	8.80
3					*10.15	9.71	*7.79	6.33	*6.66	4.55	*4.61	3.65	8.64	3.33	9.11
1.5					*12.03	9.09	*8.78	6.03	6.55	4.4	*4.92	3.54	8.70	3.23	9.17
0			*6.59	*6.59	*12.92	8.77	8.95	5.83	6.43	4.29	5.38	3.62	8.49	3.29	8.97
-1.5	*7.56	*7.56	*11.47	*11.47	*12.84	8.69	8.85	5.74	6.39	4.25	5.85	3.91	8.00	3.52	8.51
-3	*12.59	*12.59	*16.55	*16.55	*11.88	8.78	*8.90	5.78			6.89	4.58	7.16	4.04	7.73
-4.5			*13.08	*13.08	*9.62	9.03					*6.97	6.26	5.83	5.23	6.51

Option 3

Metric

Boom : 5.9m One-Piece Boom Arm : 3.5m Bucket : Without Bucket Shoe : 600mm

Unit : 1,000kg

A(m)	1.5		3		4.5		6		7.5		9		Max. Reach
7.5													*3.90
6									*5.44	4.81			*3.71
4.5							*6.22	*6.22	*5.75	4.71			*3.68
3					*9.29	9.29	*7.28	6.38	*6.28	4.55	*4.38	3.4	*3.79
1.5					*11.38	9.19	*8.37	6.05	6.54	4.38	4.95	3.33	*4.02
0			*7.52	*7.52	*12.61	8.77	8.93	5.8	6.39	4.24			*4.44
-1.5	*7.18	*7.18	*11.03	*11.03	*12.87	8.62	8.79	5.68	6.31	4.17			*5.15
-3	*11.19	*11.19	*16.07	*16.07	*12.25	8.64	8.79	5.67	6.34	4.2			*6.09
-4.5	*16.35	*16.35	*14.66	*14.66	*10.51	8.84	7.67	5.82					*6.70

1. Ratings are based on SAE J1097
2. Load point is the end of arm.
3. * Rated loads are based on hydraulic capacity.
4. Rated loads do not exceed 87% of hydraulic capacity or 75% of tipping capacity.

: Rating Over Front
 : Rating Over Side or 360 degree

STANDARD AND OPTIONAL EQUIPMENT

STANDARD EQUIPMENT

Hydraulic system

- Boom and arm flow regeneration
- Boom and arm holding valves
- Swing anti-rebound valves
- Spare ports(Control valve)
- One-touch power boost

Cabin & Interior

- Viscous cab mounts
- All weather sound suppressed type cab
- Air conditioner& Heater
- Adjustable suspension seat with head rest and adjustable arm rest
- Pull-up type front window and removable lower front window
- Room light
- Intermittent windshield wiper
- Cigarette lighter and ashtray
- Cup holder
- Hot & Cool box
- LCD color monitor panel
- Engine speed (RPM) control dial
- AM/FM radio
- Remote radio ON/OFF switch
- 12V spare powers socket
- Serial communication port for laptop PC interface
- Joystick lever with 3 switches
- Sunvisor
- Sun roof

Safety

- Large handrails and step
- Convex metal anti-slip plates
- Seat belt
- Hydraulic safety lock lever
- Safety glass
- Hammer for emergency escape
- Right and left rearview mirrors
- Travel alarm
- Battery protector cover

Others

- Double element air cleaner
- Water separator
- Fuel filter
- Dust screen for radiator/oil cooler
- Engine overheat prevention system
- Engine restart prevention system
- Self-diagnostic system
- Alternator(24V, 60 amps)
- Electric horn
- Halogen working lights(frame mounted 2, boom mounted 2)
- Hydraulic track adjuster
- Track guards
- Greased and sealed track link
- Hydraulic oil tank air breather filter

OPTIONAL EQUIPMENT

Some of these optional equipments may be standard in some markets. Some of these optional equipments cannot be available on some markets. You must check with the local DOOSAN dealer to know about the availability or to release the adaptation following the needs of the applications.

Safety

- Overload warning device
- Cabin Top/Front guard(ISO 10262, FOGS standard)
- Travel & swing alarm
- Rotation beacon
- Lock Valve
- Rear view camera

Cabin & Interior

- Air suspension seat
- MP3/CD player
- Cassette player
- Rain Shield
- ROPS cabin

Others

- Piping for crusher
- Piping for quick clamp
 - Breaker with flow control valve
 - Crusher with tilting
 - Clamshell
- 700mm/800mm/900mm shoe
- Lower wiper
- Fuel heater
- 80A alternator
- Fuel filler pump
- Working Lights
 - 4-front/2-rear on cabin
 - 2-front on cabin
 - 1 on counterweight

Undercarriage

- Narrow track frame

Doosan is

Since 1896, Doosan, the oldest company in Korea, has evolved with its people. The company grew up rapidly for last 10 years with reputation. For human-oriented vision, Doosan has been building constructions, energy, machines, infra structures globally. As a global leader of infra structure, Doosan continues its vision to make human-oriented future.

First in Korea, Doosan self-developed excavators in 1985 and continued building versatile construction machines including excavators, wheel loaders, articulated dump trucks to execute its human-oriented philosophy. Doosan became a global leader of heavy construction machine industry by achieving global sales line, producing line, and distribution line. Along with large production bases in Korea, China, USA, Czech, Brazil, Doosan has 1400 dealer networks and Doosan is providing reliable products and trusted solutions for your stable business at no risk.



Doosan Infracore Korea Office (HQ)
27F, Doosan Tower, 275, Jangchungdan-ro,
Jung-gu, Seoul, Korea(04563)
www.doosaninfracore.com/ce/

Copyright 2018. Doosan Infracore. All rights reserved.